

SHARP®

操作說明書 Operation Manual

EJ-X20H

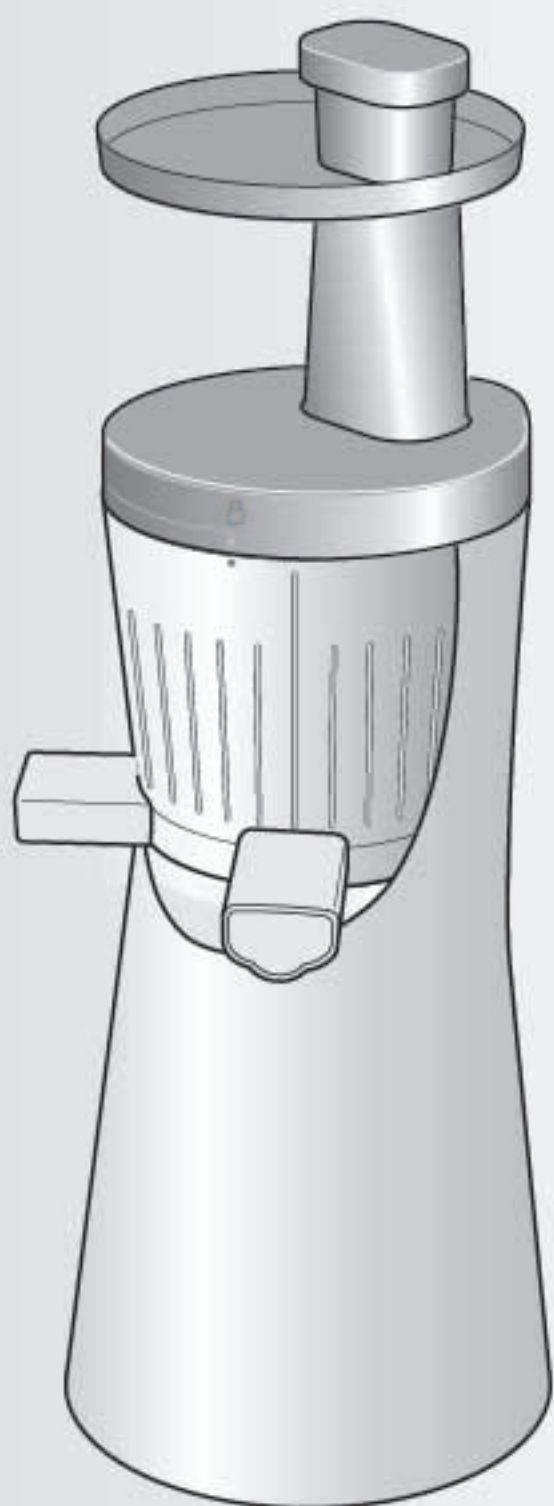

慢磨果汁機

Healsio Juicer

目錄 Contents

頁 Page

操作說明書目錄

i

Contents of the
Operation Manual

ii

請勿放入用水、果汁等液體製成的冰塊以及桃子核等堅硬的果核。關於使用方法和食材等，請詳細閱讀說明書和食譜。

Please do not put ice cube made of water, juice and other liquids, peach core as well as other hard kernels. Please read the operation manual and cookbook carefully about the usage and ingredients.

安全注意事項	C-1
重要注意事項	C-2
產品部件	C-3
安裝說明	C-4~5
使用方法	C-6~7
實用技巧（反向操作）	C-8
關於食材	C-8~9
拆卸與清潔方法	C-10
清潔技巧	C-11
故障處理方法	C-12~13
產品規格	C-13

Contents **page**

Safety Precautions	E-1
Important Safeguards	E-2
Product Components	E-3
Assembly Instruction	E-4~5
How to Use	E-6~7
Helpful Tips (Reverse Mode)	E-8
Ingredients	E-8~9
How to Disassemble and Clean	E-10
Cleaning Tips	E-11
Troubleshooting	E-12~13
Product Specification	E-13

安全注意事項

使用前，請詳細閱讀所有安全警告。



警告 為防止火災、觸電、受傷

- 為避免觸電：
 - 請勿用濕手將插頭插入或拔出電源插座；
 - 請將本機插入接地良好的電源插座；
 - 將本機插入或拔出電源插座時，請緊握插頭，拔出插頭時請勿用力拉扯電源線；
 - 清潔本機時請勿將機器浸入水中，也不要用水沖洗；
 - 如果電源線或插頭損壞，請勿使用本機器；
 - 為避免損壞電源線，請勿用力扭曲或彎折電源線。
- 為避免受傷和使機器受損，請勿在使用過程中拆卸機器。
- 請將機器放置於兒童接觸不到的地方。
- 拆卸機器後請勿使用機器。本機器僅可在完全組裝後使用。
- 機器運轉時請勿將手指或身體的任何部位放入機器，請按要求僅限使用“推料棒”輔助推動食物。
- 使用時，請將本機器放置於適合放置廚具的穩固、平坦的平面上。
如果出現以下情況，請勿使用本機：
 - 機器有異味、發熱或冒煙；
 - 機器曾經摔落或有損壞痕跡；
 - 螺旋擠壓器損壞。
- 請勿嘗試自行修理本機。應由合資格的專業維修人員對本機進行維修。
- 請確保榨汁完成後關閉機器。
- 請僅用乾燥的手接觸電源按鈕。
- 此產品不適合身體有殘障或智力障礙的人仕單獨使用，包括缺乏知識和經驗的兒童。除非他們在監護人的監護和指導下才可使用本產品。
尤其需注意不要讓兒童將此產品當玩具來玩耍。



注意 為防止漏電、受傷、避免家庭財產等受到損傷

- 如使用過程中機器出現堵塞或暫停，請將機器轉換至“REV”模式，約3秒鐘後再轉換至“ON”模式，這樣可以清除機器中堵塞的食物。
- 在機器運轉時請勿堵塞果渣出料口。

- 請用雙手來移動或提起本機。
- 每次使用本機請勿超過20分鐘，使用時間過長會使機器過熱，可能導致馬達故障。
- 機器內無蔬果食材時請勿運轉本機。機器空轉幾秒鐘可能導致某些零件部份因缺少潤滑而磨損。
- 使用後，請徹底清潔本產品。
- 請勿過多、過快地放入蔬果食材。否則果汁可能會向上溢出。
- 請勿使用除推料棒以外的器具推壓蔬果食材。否則可能會導致本產品嚴重損壞。
- 請勿將本機用於磨碎穀物。
- 根據不同的食材，
 - *可能會有果渣殘留在盛料杯內。
 - *使用結束後，盛料杯有可能較難打開（煮熟的大豆、製作雪葩時等）。
 - *可能會使果汁分離。
- 運轉中請勿移動機器。
- 果核大而堅硬的食材，例如桃，請勿直接放入機器。
- 移動機器時，請拔下電源插頭，分別緊握盛料杯和機身。

重要注意事項

使用電器時應遵守以下基本安全保障措施：

- 閱讀本手冊中所有操作說明事項。
- 僅限在熟悉所有操作步驟和使用說明後方可使用本產品。
- 本產品是專為家用用途設計，請勿將本書推薦以外的食材或其他任何物品放入本產品內。
- 在不使用本產品時或清洗本產品前，請將電源線從電源插座中拔出。
- 僅限使用為本產品專門配備的配件。
- 請勿在戶外使用，本產品是為室內使用而設計的。
- 使用本產品時，請勿將本產品靠近加熱器或加熱裝置。

產品部件

主機和零件

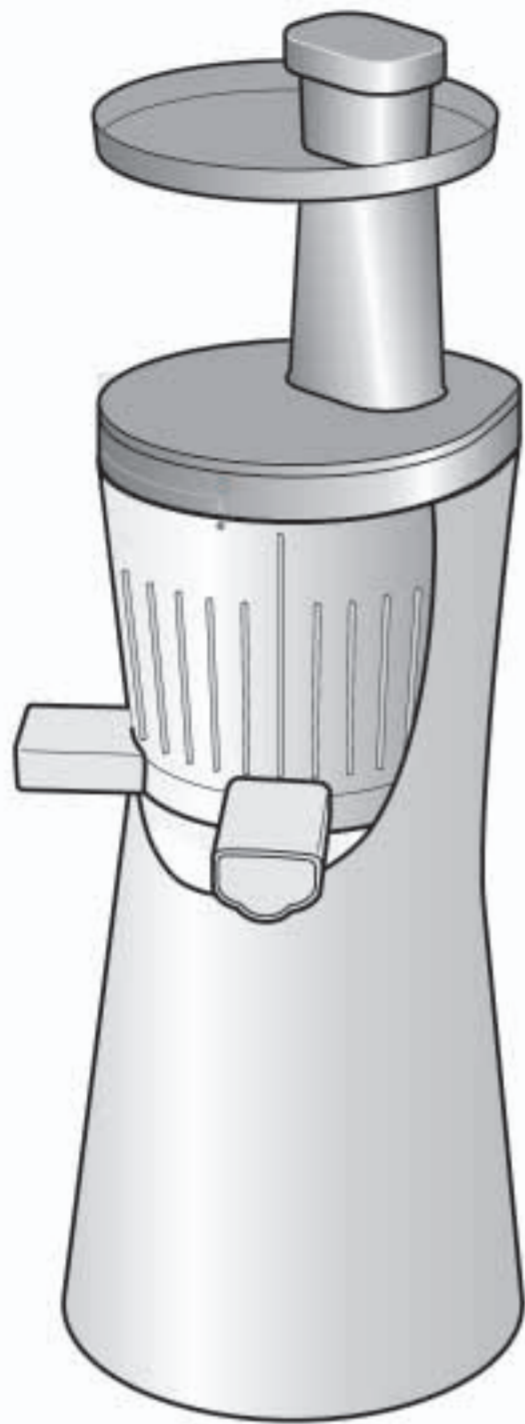

推料棒

進料斗

螺旋擠壓器

橡膠墊

盛料杯

雪葩出口/
果渣出口
果汁出口

主機

開關

電源線

配件

盛渣杯

盛汁杯

果汁蓋

清潔刷

雪葩專用配件

C-3

安裝說明 (拆卸方法)

拔下電源插頭，在穩固、平坦、乾燥的水平面上進行安裝。

盛料杯

① 安裝盛料杯橡膠墊 (灰色)

※購買新機時已預先安裝好橡膠墊。

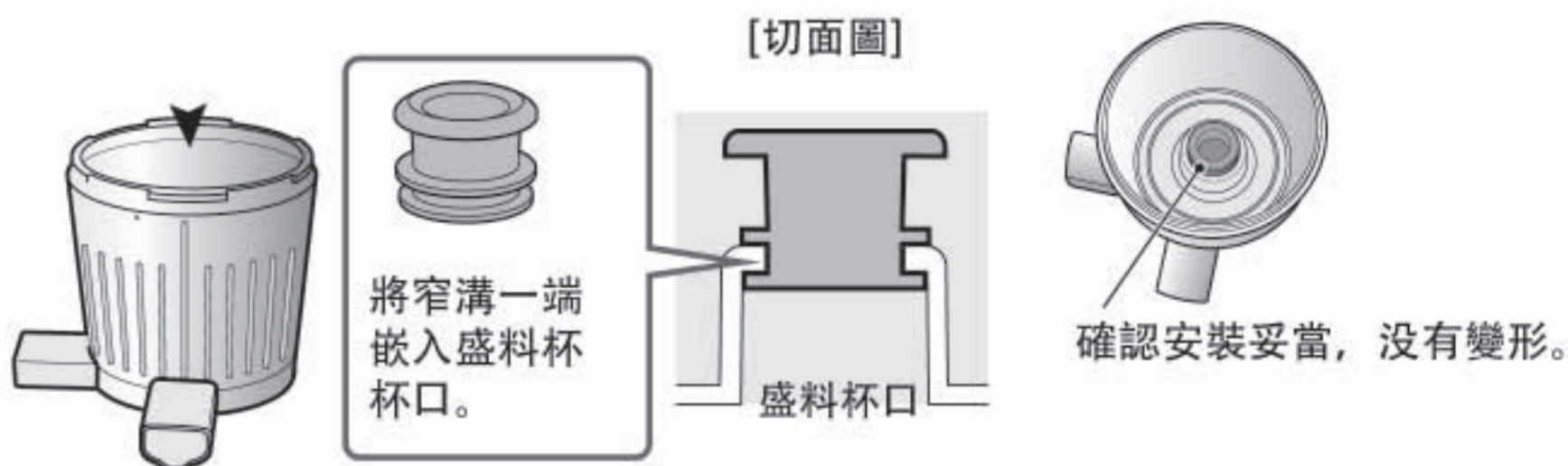

② 插入盛料杯橡膠墊(黃色)

※購買新機時已預先安裝好橡膠墊。
用水沾濕橡膠墊，會較容易插入。

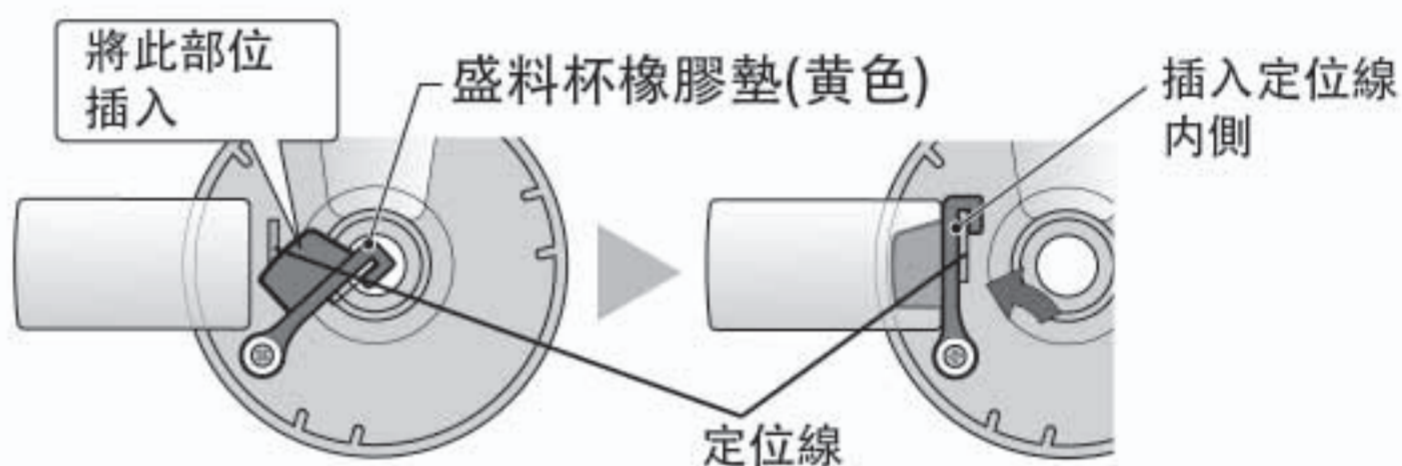

- 1.如果插入不到位，可能會漏出果汁和雪葩。
- 2.清洗時請拔出橡膠墊 (黃色)。

③ 盛料杯凹陷處對準主機凸起處，將盛料杯安裝在主機上。

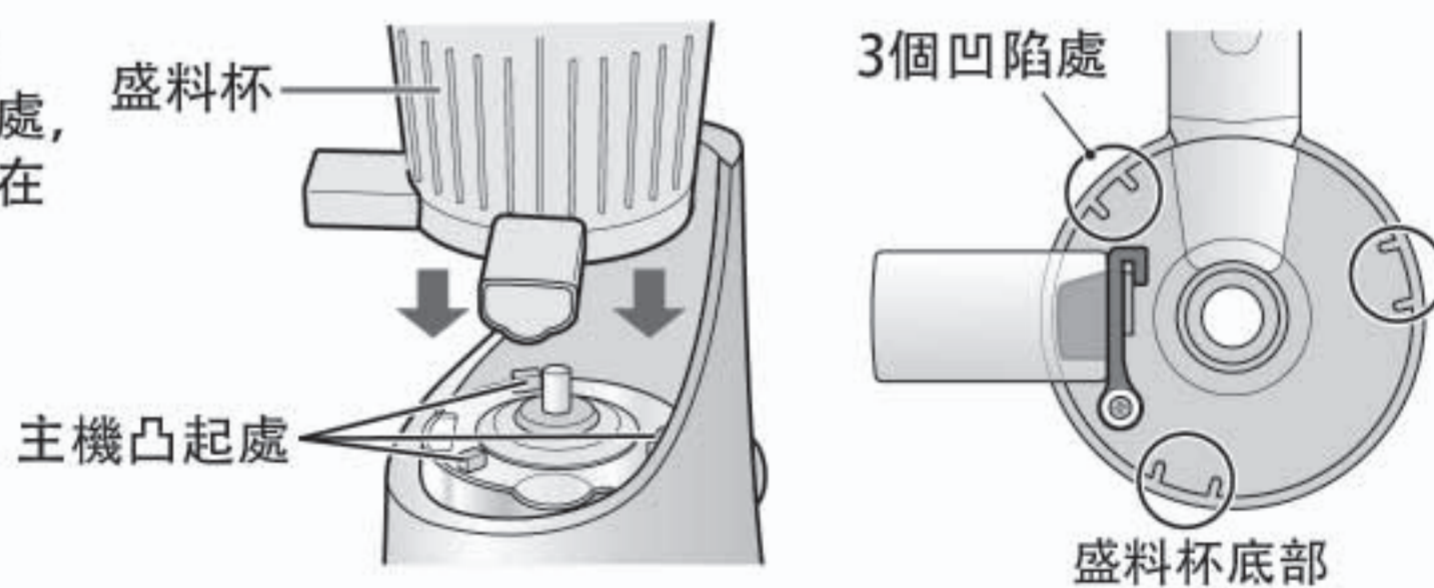

④ 將濾網橡膠墊 (灰色) 安裝在濾網上。

※購買新機時已預先安裝好橡膠墊。

製作雪葩時
請看 ⑤



把橡膠墊的 ○ 部位掛上去，直接往下拉，使○部分掛在下側。

螺旋擠壓器

安裝說明 (拆卸方法)

拔下電源插頭, 在穩固、平坦、乾燥的水平面上進行安裝。

螺旋擠壓器

進料斗

果汁蓋

5 將濾網安裝到螺旋擠壓器上。

製作雪葩時
不使用濾網, 要安
裝雪葩專用配件。

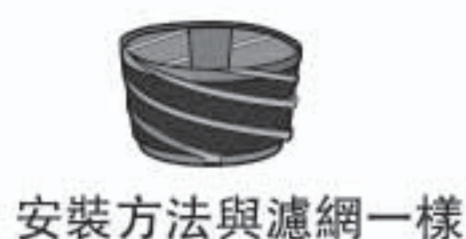

螺旋擠壓器

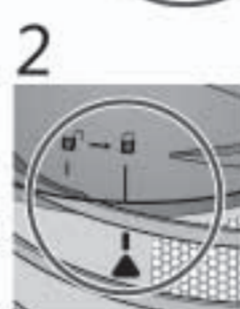
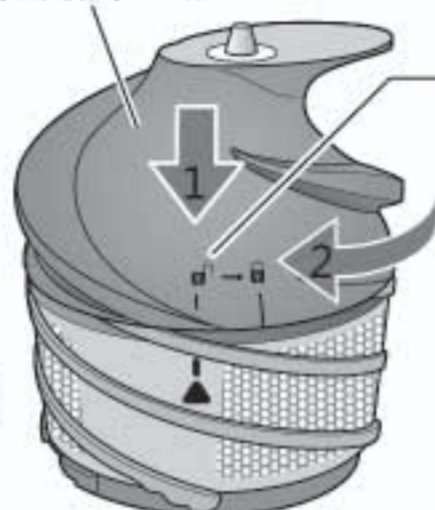

對準標誌。
(取下時也要對準)



向左旋轉螺旋
擠壓器並鎖定。
確認濾網穩固
地接合。

6 將螺旋擠壓器插入盛料杯的旋轉軸。

左右旋轉, 確認已經插到底部,
不能再往下推了。
如果插不到位, 進料斗將無法蓋上。

- 請注意, 手指不要卡在螺旋擠壓器與盛料杯之間的縫隙裡。

盛料杯

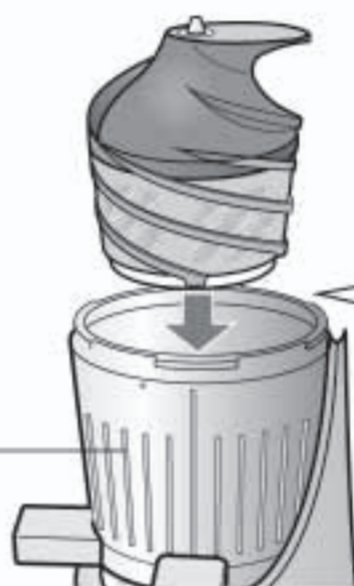

螺旋擠壓器
不能高出盛料杯。

7 進料斗的○對準盛料杯的●後, 向左旋轉, 直至進料斗的○與盛料杯的●對齊。

○ (開)

○ (關)

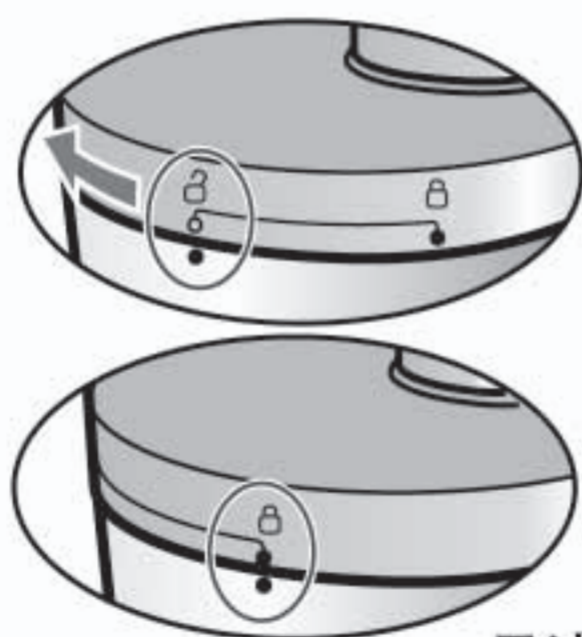

果汁蓋的安裝說明

- 製作果汁時, 為防止剩餘果汁滴落, 您可以關上果汁蓋。
- 製作雪葩時, 請務必安裝並關上果汁蓋。



果汁蓋

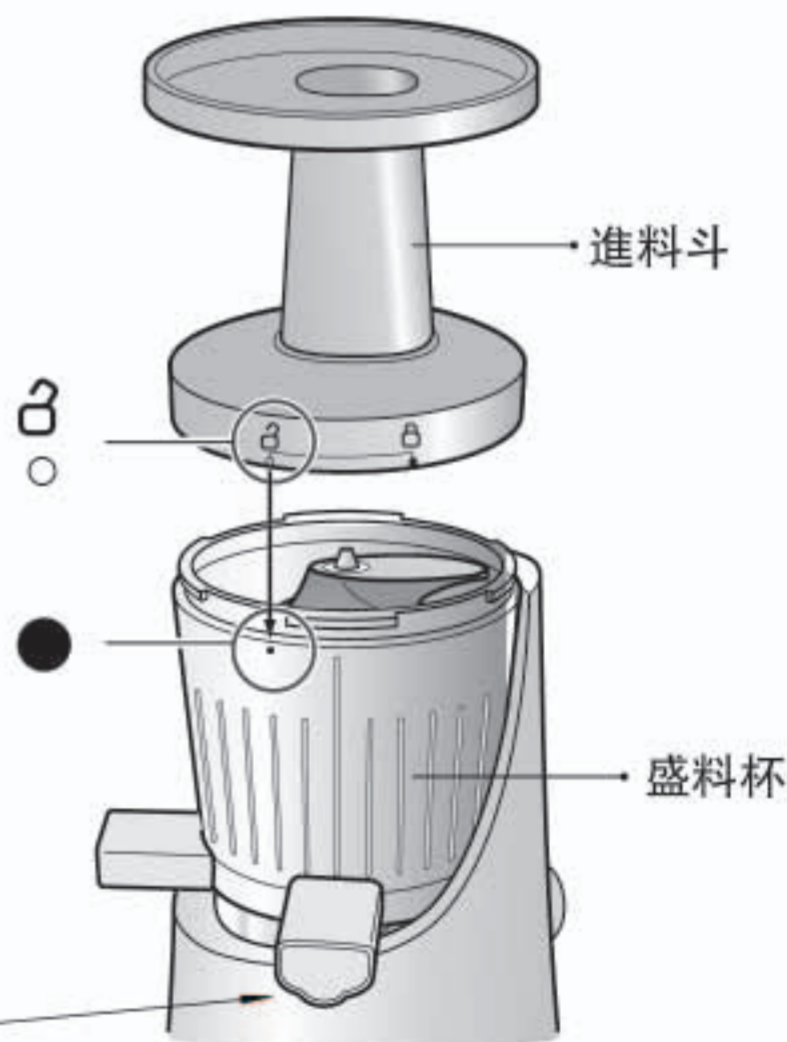

進料斗

盛料杯

進料斗安裝到位的話,
會發出“卡”聲。

使用方法 (準備)

本產品有榨汁用過濾網和雪葩專用配件，請務必根據用途分開使用。為防溢漏，請確認盛料杯橡膠墊（黃色・灰色）已正確安裝。第C-4頁

製作果汁

食材的準備工作請看食譜第C2~C4頁

- 1 安裝榨汁用濾網C4~C5頁 
- 2 將盛汁杯和盛渣杯分別放在果汁出口與果渣出口下方。
- 3 打開果汁蓋。
- 4 插上電源插頭。



不可使用的食材

會導致機器故障，切勿放入。

- ・冰塊 ・甘蔗、乾燥大豆等豆類
- ・桃子等的果核 ・冷凍食材
- ・柿子（柿子核可能無法去除乾淨）
- ・食譜上沒有寫到的乾燥食材（可能會損壞零件部分）

要點：

- ・投放食材時，關鍵是“每次少量，保持一定間隔”。搭配不同食材榨汁時，要交替放入，這樣容易混合在一起。
- ・食材塞得過滿時，螺旋擠壓器不能順利擠壓食材，可能導致難以榨汁。如發生堵塞，請清除食材，清洗機器。
- ・將蔬果食材徹底清洗乾淨後才放入機器。
- ・果渣有可能混入果汁。如果介意，請過濾之後飲用。

製作雪葩 *

食材的準備工作請看食譜第C13~C14頁

- 1 安裝雪葩專用配件C4~C5頁 
如果使用榨汁用濾網製作雪葩，可能會毀壞濾網。
- 2 將盛汁杯放在雪葩出口下方。
- 3 務必關閉果汁蓋。
- 4 插上電源插頭。
- 5 食材從冷凍室取出後解開包裝，在室溫下放置2~3分鐘。

等食材能用菜刀輕鬆切開時，就是放進去製作雪葩的最佳硬度。如果還切不開，就在室溫下繼續放置一會。

* 使用冷凍的水果、蔬菜、乳酪等冷凍食材，安裝雪葩專用配件，製作雪葩。

不可使用的食材

會導致機器故障，切勿放入。

- ・冰塊 ・甘蔗、桃子等的果核

要點：

- ・製作雪葩時，盛料杯中可能出現食材堆積。大約投入300克食材後（製作的雪葩大約在盛汁杯的200毫升時），請清洗一下盛料杯內部。
- ・盛料杯、雪葩專用部分等配件裡可能會有雪葩殘留。盛料杯裡殘留的食材請用刮板等比較軟的工具清除乾淨。

使用方法

- 1 按下電源開關“ON”鍵（開關上部）。

為防止空轉，啟動後請立即放入食材。



- 2 每次少量，保持一定間隔，將食材放入進料口。

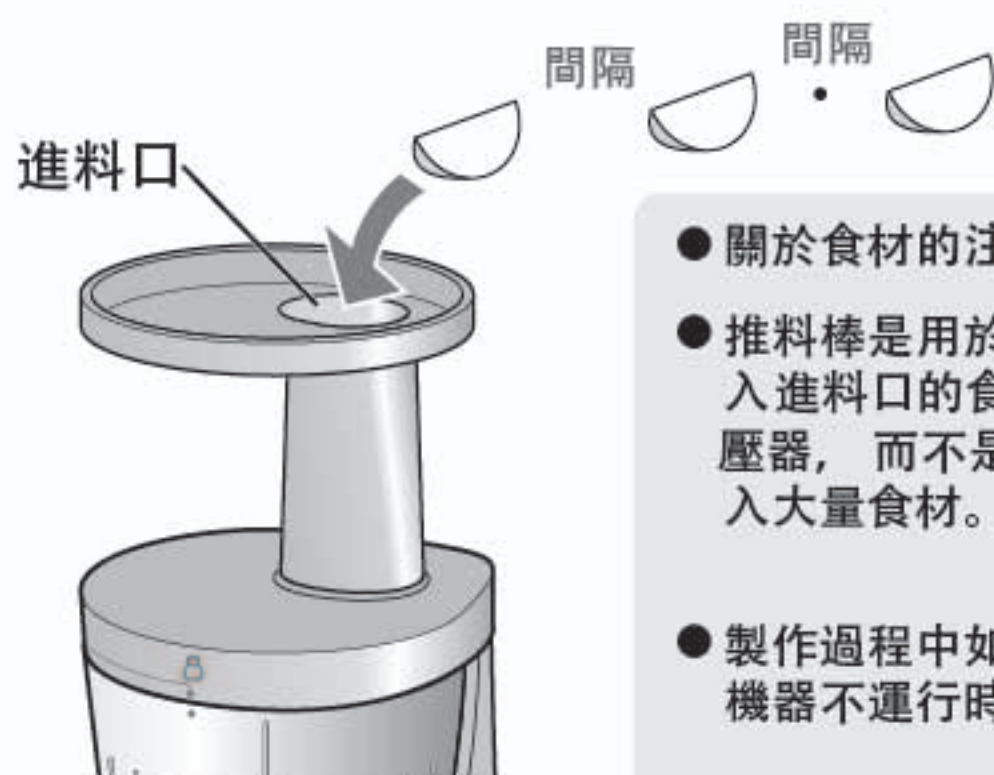

- 關於食材的注意事項請閱讀C8~C9頁。

- 推料棒是用於將無法順利放入進料口的食材推入螺旋擠壓器，而不是用來一次性塞入大量食材。

- 製作過程中如果出現食材堵塞、機器空轉、機器不運行時，請使用反向操作C-8頁。

製作果汁時

螺旋擠壓器慢速擠壓食材，果汁和果渣分別從各自的出口流出。

根據食材的新鮮度和收穫時期，製作出的果汁量會有所不同。

當果渣流出速度變慢時，請按下電源開關“關”鍵，清除食材，清洗機器。

建議榨汁時不宜連續放入超過1公斤的蔬果食材，否則果汁中可能混入較多果肉。冷藏餘下未食用的果汁。

製作雪葩時

等食材進入製作雪葩專用配件之後，再接着放入其後的食材。

螺旋擠壓器慢速擠壓食材，雪葩會從雪葩出口流出。當螺旋擠壓器速度變慢時，請暫停放入食材，等速度恢復正常之後再放入。

- 3 製作完畢，輕按電源開關的“OFF/REV”鍵，讓機器停下。



- 請注意，用力按住開關下部，將啟動反向運轉。

- 使用完畢後，請拔下電源插頭，清洗機器。(C10頁)

- 製作雪葩時，盛料杯裡殘留的食材請用刮板等較軟的工具清除乾淨。

實用技巧(反向操作)

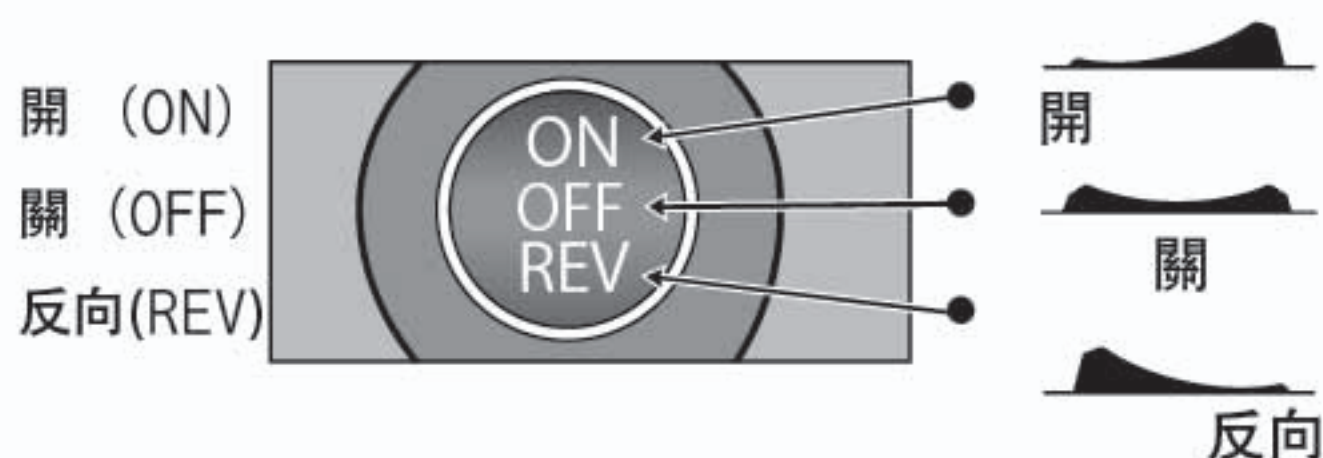

1. 關閉機器。
2. 將慢磨果汁機調至“反向”模式數秒。
3. 重新啓動本產品。
4. 如果“反向”模式不運行，則拆卸本產品，然後根據安裝說明重新安裝。
5. 重新啓動本產品。



本產品開啟前，電源開關必須完全乾燥。

關於食材

榨汁時

C6~C7頁

- 請使用新鮮的食材
- 橘子、橙子、檸檬等柑橘類水果
 - 去除外皮，切成大小合適的小塊。
 - 籽和內果皮可不清除，直接放入。
- 香蕉、菠蘿、奇異果等需要剝皮食用的蔬果
 - 需去皮。
- 菠蘿、玉米等有硬芯的蔬果。
 - 需去除硬芯。
- 胡蘿蔔、蘿蔔、生薑等皮也可食用的蔬菜。
 - 無需剝皮，可直接放入。
- 蘋果
 - 去蒂，切成半月形。
 - ※ 蘋果等容易變色的水果，榨成果汁之後過了一段時間也會變成褐色。
- 西瓜、蜜瓜
 - 去皮，籽可不清除，直接放入。
- 桃子等果核又大又硬的蔬果
 - 去核。
 - 可不削皮，直接放入。
- 菠菜、捲心菜、橄欖菜等纖維多的蔬菜
 - 切小塊。
 - 菠菜、捲心菜等的榨汁表面會浮着一層泡沫，可直接飲用。如果介意，請用湯匙等撇去浮沫再喝。

關於食材

榨汁時 C6~C7頁

投放食材的要點 (榨汁時)

- 注意，放入食材或打開進料斗時，果汁等有可能會飛濺出來。
- 用煮熟的大豆、香蕉等食材水分少，請和水或牛奶一起放入進料口，否則榨汁效果不佳。
- 胡蘿蔔水分少、纖維多，榨剩的果渣就會比較多。
- 葉類蔬菜可搭配水分多的果肉一起榨汁，這樣較容易榨出果汁。
- 有莖有葉的蔬菜，請將莖、葉分開，交替放入。
- 香蕉、奇異果、草莓等食材，大部分果肉可能會出現在果渣里。
- 菠菜、捲心菜等葉類蔬菜及其他切成薄片的食材有可能會夾在螺旋擠壓器與過濾器之間的縫隙裡，影響機器運轉。若出現這種情況，請執行“反向操作”C-8頁
- 榨捲心菜等時，機器運行過程中可能會發出較大的聲音。
- 請勿使用乾燥食材。大豆等食材請預先加熱或用水充分浸泡變軟後使用。
- 果核小的（如蘋果、葡萄、西瓜等）蔬果可以直接連籽帶肉一起放入。果核大的（如桃子等）蔬果，請先去核再放入。

製作雪葩時 C6~C7頁

- 使用預先冷凍好的食材。
- 將食材切小塊，以便能放入進料口。切好後平鋪裝進冷凍袋裡面冷凍，注意不要互相重疊。放入進料口之前，若食材黏在一起了，要用手掰開再放入。
- 乳酪等軟的食材可以使用製冰器，這樣比較方便。（不能使用水、果汁等液體）
- 橘子、橙子等柑橘類水果
 - 剝皮，去籽，切成月牙形。
 - 削淨內果皮雪葩口感會更柔滑。
- 菠蘿、奇異果
 - 剝皮，有芯的要去芯。
- 香蕉
 - 剝皮，切成2厘米厚的圓片。
- 蘋果、甜椒、番茄
 - 去蒂、去芯、去籽。削皮之後口感會更柔滑。
- 胡蘿蔔、南瓜等
 - 切成2厘米大小的方塊，用水煮軟。
- 菠菜等
 - 先用水煮軟，再切成2~3厘米長。
- 市面上銷售的冷凍水果
 - 可直接使用。
- 市面上銷售的切好的水果
 - 剝皮、去籽。
- 罐頭
 - 瀝乾水分。

投放食材的要點

- 請勿使用剛從冰箱拿出來的食材。請在室溫下放置 2-3 分鐘。
等食材能用菜刀輕鬆切開時，便是放進去製作雪葩的最佳硬度。
- 請勿窺視進料口。
（食材有可能會濺出來。）
- 若放入堅硬的食材，機器運轉過程中可能會發出較大的聲音。
- 螺旋擠壓器的旋轉速度變慢時，請暫停放入食材。等速度恢復正常之後再放入。

拆卸與清潔方法

1 關閉機器,切斷電源。

2

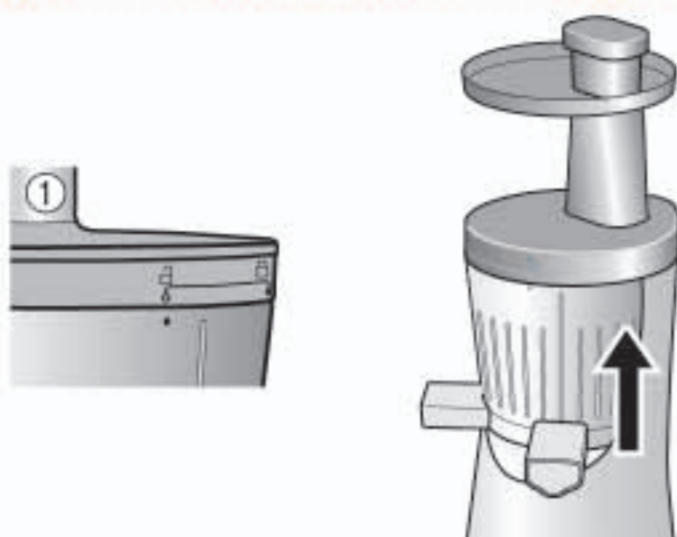

抓住並旋轉進料斗來解鎖。
拆卸盛料杯前,請確保進料斗上的“開鎖鍵”(○)與盛料杯上的“開關鍵”(●)對齊。

3

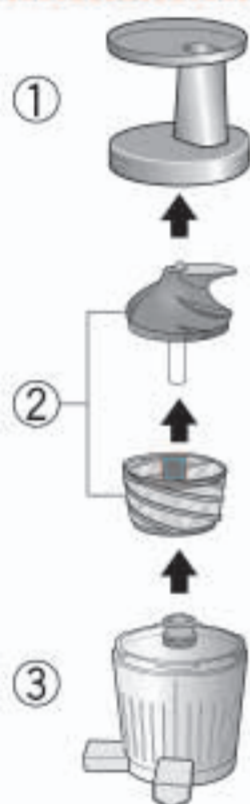

拆卸次序

- ① 進料斗
- ② 螺旋擠壓器
- ③ 盛料杯



如果榨汁過程中使用了“反向”模式,可能會導致螺旋擠壓器上下脫離,取出時請注意,避免掉落。

4

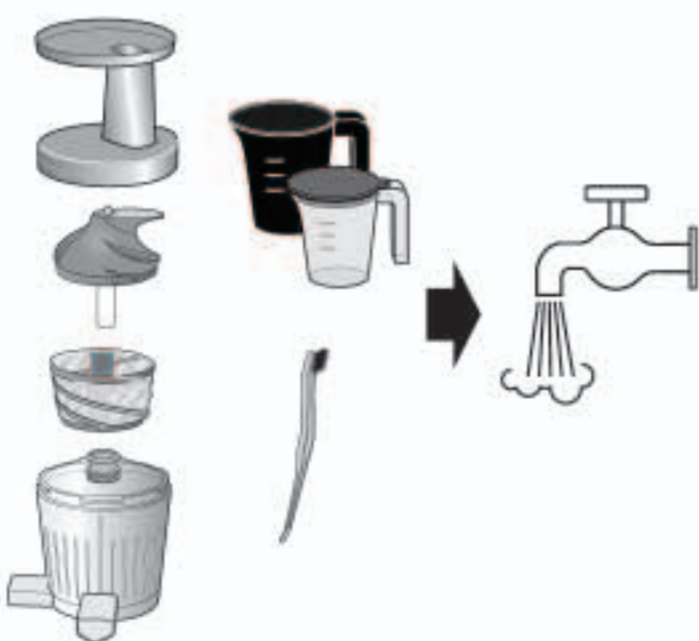

使用後請用刷子徹底清潔螺旋擠壓器。



請用柔軟的濕毛巾清洗。請勿使用洗碗機或高溫清潔器清洗。

由於螺旋擠壓器本體較重,建議將其放在盛料杯中移動至清洗處。

清洗後請晾乾所有的部件。

5



請勿使用加熱器乾燥部件。
請確保所有移動部件均徹底洗淨以避免發霉。

清潔技巧

為了方便清洗，我們建議將螺旋擠壓器分解後進行清洗。

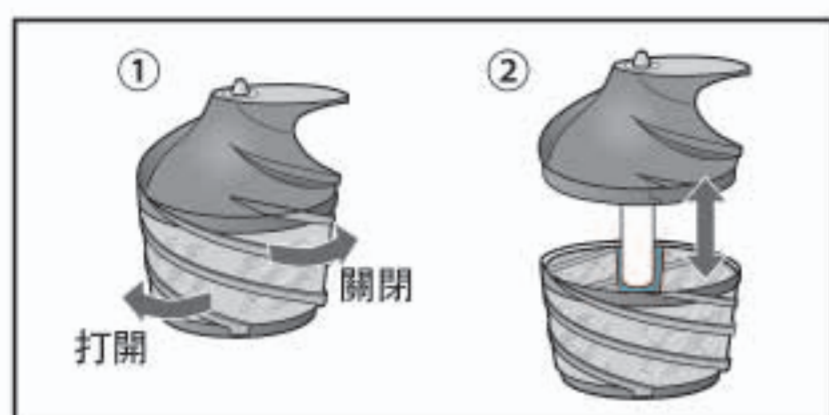

分解方法如左圖。

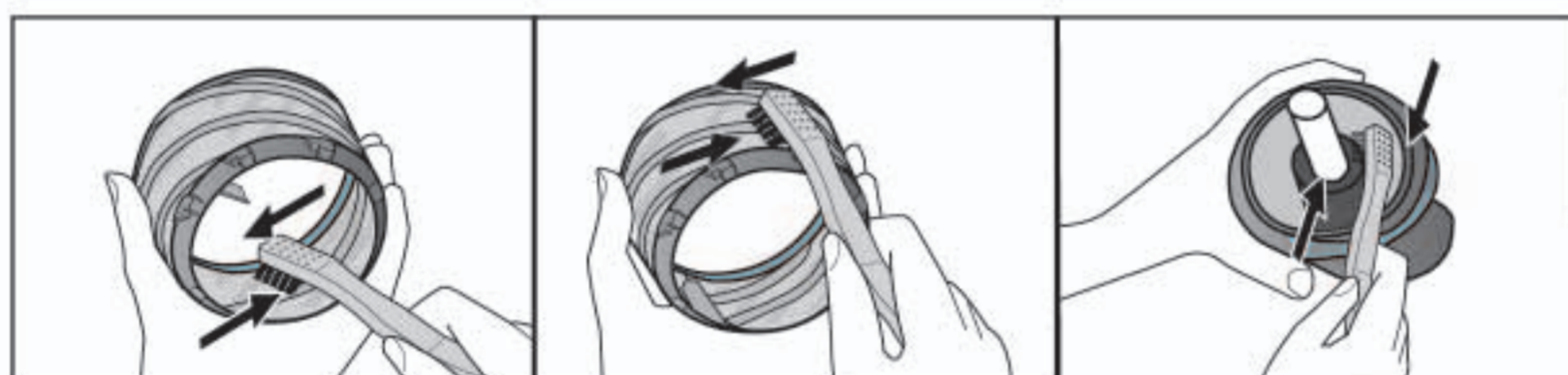

請使用提供的專用清潔刷清洗過濾器的內部和外部，以及螺旋擠壓器的內部。使用後請立即清洗本產品。



提示

使用專用清潔刷清潔後，請將過濾器和螺旋擠壓器置於自來水中沖洗。即可沖洗出剩餘果渣。

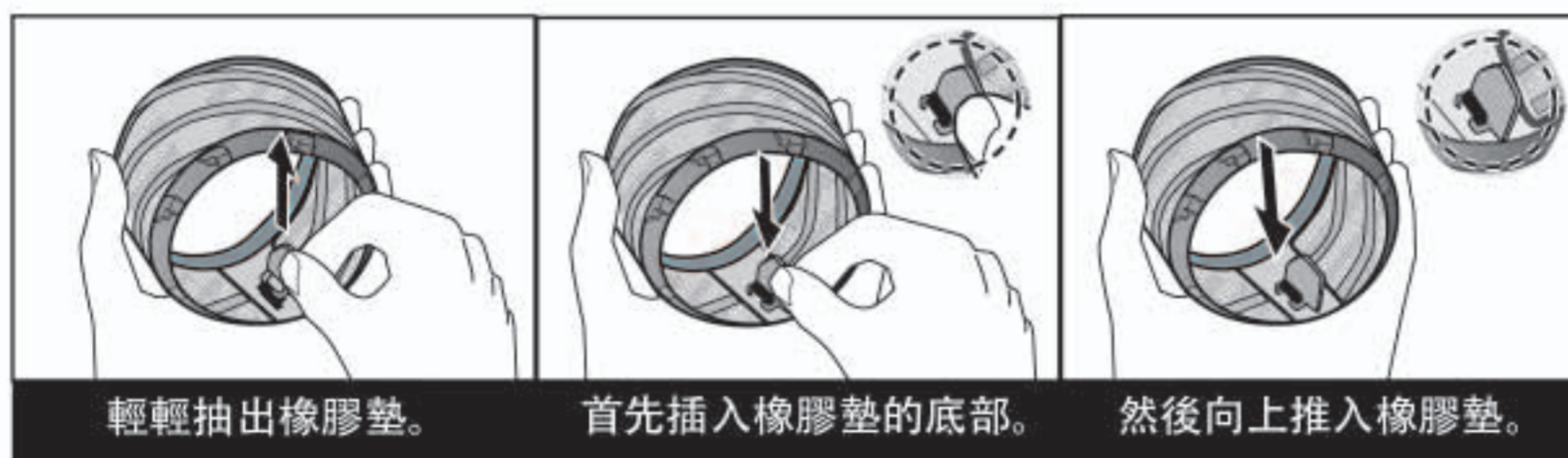

請取下橡膠墊後，徹底清潔過濾器的內部。



提示

- 請勿使用含有及溶劑（溶劑、稀釋劑等）、漂白劑、氯、苯或研磨劑的清潔劑清潔慢磨果汁機的任何部分。
- 使用後請勿將尚未清洗的機器存放起來，請立即清洗。
- 請勿將主機放入水中或其他液體中沖洗或浸泡。
- 如有需要，請使用柔軟的毛巾清潔主機。

故障處理方法

用戶可能因不熟悉產品使用方法而導致對本產品的不當操作。

請對照以下幾點解決上述問題。

如果執行以下步驟後仍無法解決問題，請聯繫服務中心。

問題	檢查	可行的解決方案
本產品不運行。	• 電源線是否已連接？	檢查電源線是否已插入220~240V、50赫茲的電源插座？
	• 慢磨果汁機是否已正確安裝？	請按照操作說明書中描述的方法安裝產品。 (請參照第C-4~5頁)
	• 是否停電了？	
	• 您是否已經使用慢磨果汁機超過20分鐘？	關閉產品。一段時間後再啟動產品。 如果您希望連續使用本產品，請在操作結束後間隔1小時再使用。
果汁太濃或太稀。	• 橡膠墊是否已正確安裝？	請按照操作說明書中描述的方法安裝橡膠墊。 (請參照第C-4頁‘橡膠墊的安裝’)
	• 使用的原材料是否新鮮？	熟透的蔬果可能會卡住馬達。 如果您希望使用熟透的蔬果的話，請將蔬果放在礦泉水水中浸泡10分鐘以後再放入本機中。
	• 您是否在機器中放置了過多原材料或其他東西？	請勿在機器中放入過多食材或液體。 我們建議您在使用1公斤材料榨汁後清洗機器。 拆卸並清洗盛料杯。
盛料杯蓋太緊，打不開。	• 您是如何打開盛料杯蓋的？	食材是否放入過多？按下“REV”按鈕，將盛料杯朝着“  ”的方向打開。 * 打開盛料杯時檢查方向是否正確。 * 製作雪葩時，請等待片刻後再打開進料斗，食材溶化後會較容易打開。
機器在操作時停止。	• 您是否強行將食物塞進慢磨果汁機中？	請勿放入過多食材。
	• 您是否使用了帶硬籽的食材？	按下“REV”按鈕，持續2至3秒鐘，然後再按下“ON”按鈕。 * 遵循以上步驟後，如果螺旋擠壓器仍不旋轉，請停止使用本產品。關閉本產品後拆卸並清洗。重新安裝後，然後再次使用啟動慢磨果汁機。
馬達運轉時發出過大噪音並震動。	• 您是否檢查了所有部件均正確安裝到位？ • 製作雪葩時，食材是否在能用菜刀輕鬆切開的程度時放入的？	如果產品安裝正確，使用過熟的蔬果食材榨汁而發出噪聲屬正常現象。 關閉本產品並清洗容器。 放入冷凍蔬果時，等食材進入雪葩專用配件之後，再接着放入其後的食材。

故障處理方法

問題	檢查	可行的解決方案
榨不出果汁	· 葉類蔬菜等食材在運轉過程中汁液有時很難榨出來。	請執行反向操作。(C-8頁)
果渣中水分很多	· 請檢查濾網是否堵住了。 請參照第C-11頁)	
使用時容器會晃動。	· 此為榨汁時的正常情況。如果本產品過熱，請聯繫維修服務中心。	
盛料杯與主機之間的縫隙有果汁泄漏	· 請檢查盛料杯橡膠墊（黃色、灰色）是否正確安裝了。(請參照第C-4頁)	
盛料杯蓋合不上	· 請檢查盛料杯橡膠墊（灰色）是否正確安裝了。(請參照第C-4頁) · 請檢查螺旋擠壓器和濾網（或者雪葩專用配件）是否正確安裝了。(請參照第C-5頁) · 請檢查螺旋擠壓器是否完全安裝在盛料杯上。(請參照第C-5頁)	

產品規格

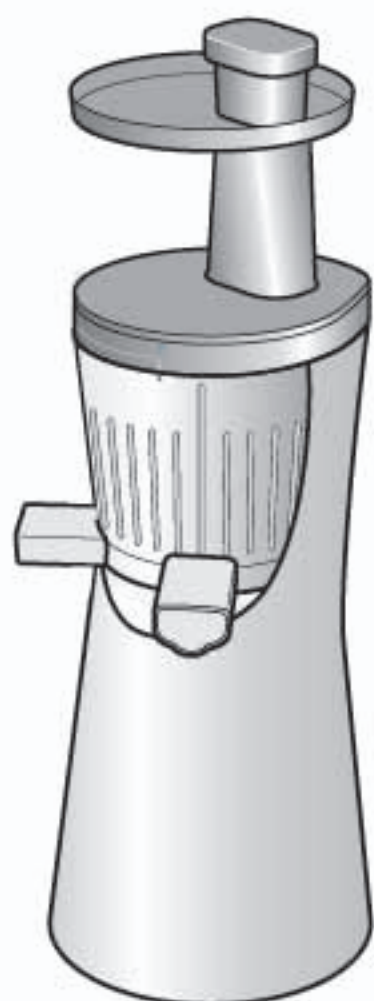

規格

型號名稱	EJ-X20H	
額定電壓	220-240V	
額定頻率	50Hz	
額定功率	150W	
每分鐘轉速	32轉/分鐘	
電線長度	1400mm	
馬達	低速直流馬達	
重量	淨重	4.8kg
	毛重	6.5kg
尺寸	闊	150mm
	深	177mm
	高	447mm
額定使用時間	持續運行少於20分鐘	

Safety Precautions

Please read all safety warnings carefully before use.



Warning: To prevent fire, electric shock and injury.

- To avoid electric shock;
Do not plug or unplug the unit into a power socket with wet hands,
Only plug the unit into a correctly grounded power socket,
Hold the power plug firmly when plugging or unplugging the unit, do not pull on the power cord when unplugging,
Do not submerge or hold the unit under running water when cleaning,
Never use the appliance if the power cord or power plug is damaged,
To avoid damage to the power cord, avoid severe twists and bends in the power cord.
- To avoid injury and damage, never disassemble the machine during use.
- Keep out of reach of children
- Never operate the machine when it is disassembled it should only be used when it is fully assembled
- Never put your fingers or any body parts into the unit when it is operating, only use the “pusher” to put foods into the unit if required.
- Always operate the unit on a flat firm surface suitable for kitchen appliances.
Do not operate the unit if;
There are any unusual odors, heat or smoke,
The unit has been dropped or has any signs of damage,
The “squeezing” screw has been damaged
- Do not attempt to make any repairs to the unit yourself, repairs should be carried out by a qualified person.
- Please ensure to turn off the machine after juicing.
- Only touch the power button with dry hands.
- This appliance is not intended for use by persons (including children) with reduced physical sensory or mental capabilities, or lack of experience and knowledge, unless they have been given supervision or instruction concerning use of the appliance by a person responsible for their safety.
Children should be supervised to ensure that they do not play with appliance.



Caution: To prevent electric leakage, injury and harm to family and property.

- If the unit jams and stops during use, switch the unit into “REV” for around 3 seconds, then back to “ON” this should dislodge the food causing the jam.
- Do not block the pulp outlet while the unit is operating.

- Use both hands when moving or lifting the unit.
- Do not use the product for more than 20 minutes at a time, excessive use can cause overheating which can lead to motor failure.
- Do not operate the unit without fruit or vegetables for more than a few seconds, some parts can become damaged due to lack of lubrication.
- Clean the product thoroughly after use.
- Do not insert too much ingredients. Do not insert ingredients too fast. Otherwise, juice may leak upwards.
- Do not use any utensils other than the pusher. Otherwise, serious product damage may occur.
- Do not use the product for grinding grain.
- In accordance with different ingredients ,
 - * Some fruit pulp may stay in drum for containing material.
 - * After the usage, drum may be difficult to open (such as poaching soybeans, making frozen food and so on).
 - * Juice is likely to separate.
- Do not move the running machine.
- Do not directly put food such as peaches with large and hard seed into the machine .
- To move the machine, please unplug the power plug, hand-hold the drum and machine body respectively .

IMPORTANT SAFEGUARDS

When using electrical appliances, basic safety precautions should always be followed including the following:

- Read all instructions in this manual.
- Only use the product when you are familiar with all instruction and operating procedures.
- This appliance is intended for household use, do not put anything other than foods recommended in this book into the appliance.
- Unplug the unit from the power outlet when not in use and before cleaning.
- Only use the attachments provided with the product.
- Do not use outdoors, the unit is designed for indoor use only.
- Do not use the product next to a heater or heating device.

Product Components

Main Body and Components

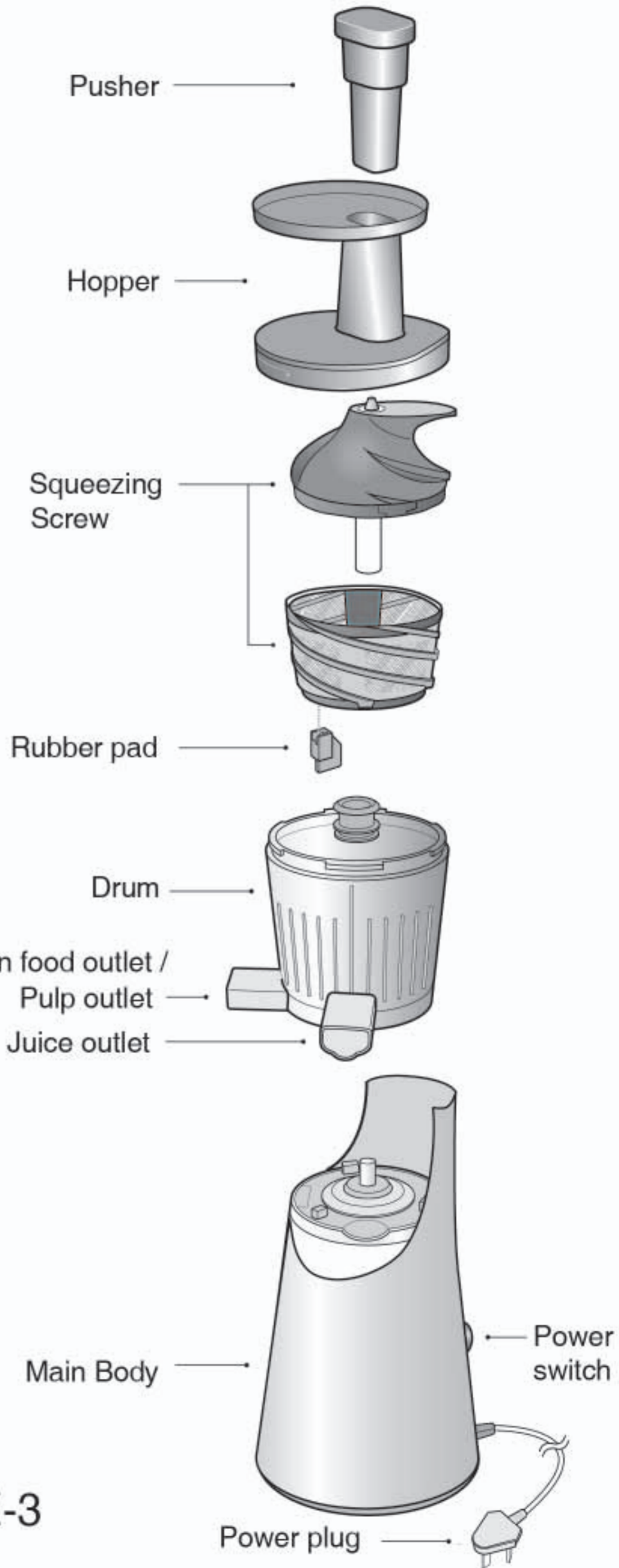
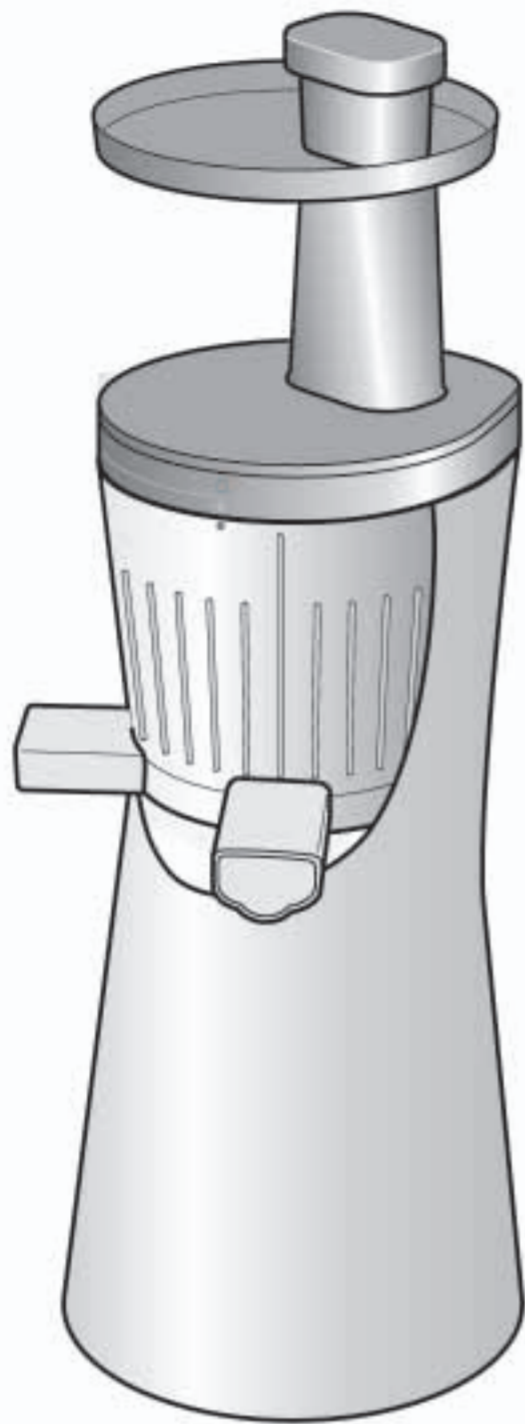

Attachment

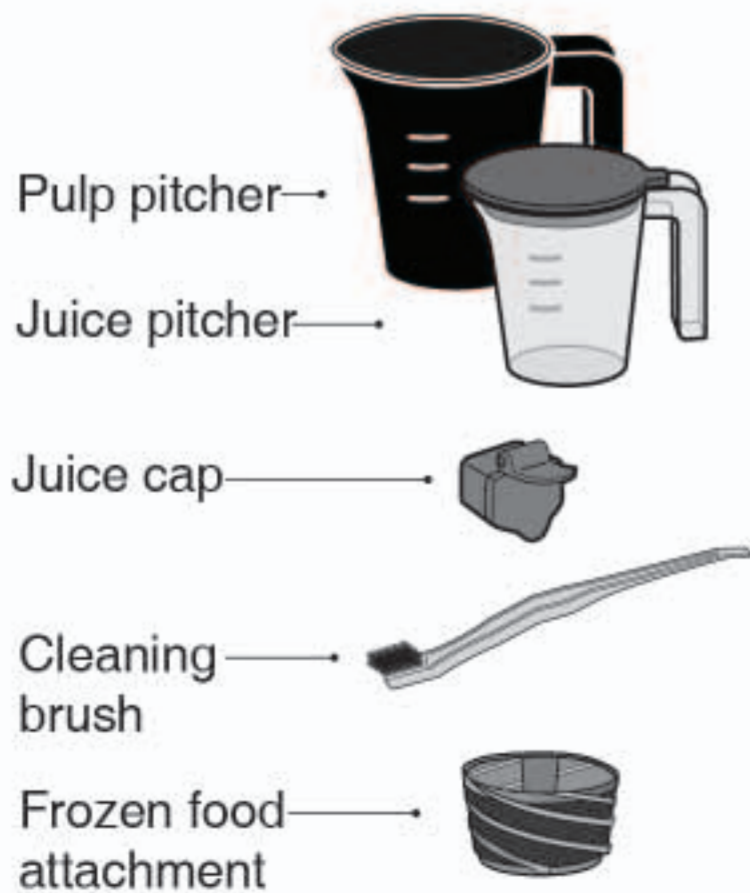

Assembly Instructions

(how to disassemble)

Disconnect the power cord and assemble the appliance on a stable, flat, dry, horizontal surface.

Drum

1 Attach the rubber pad (gray).

※ It is attached when purchased.

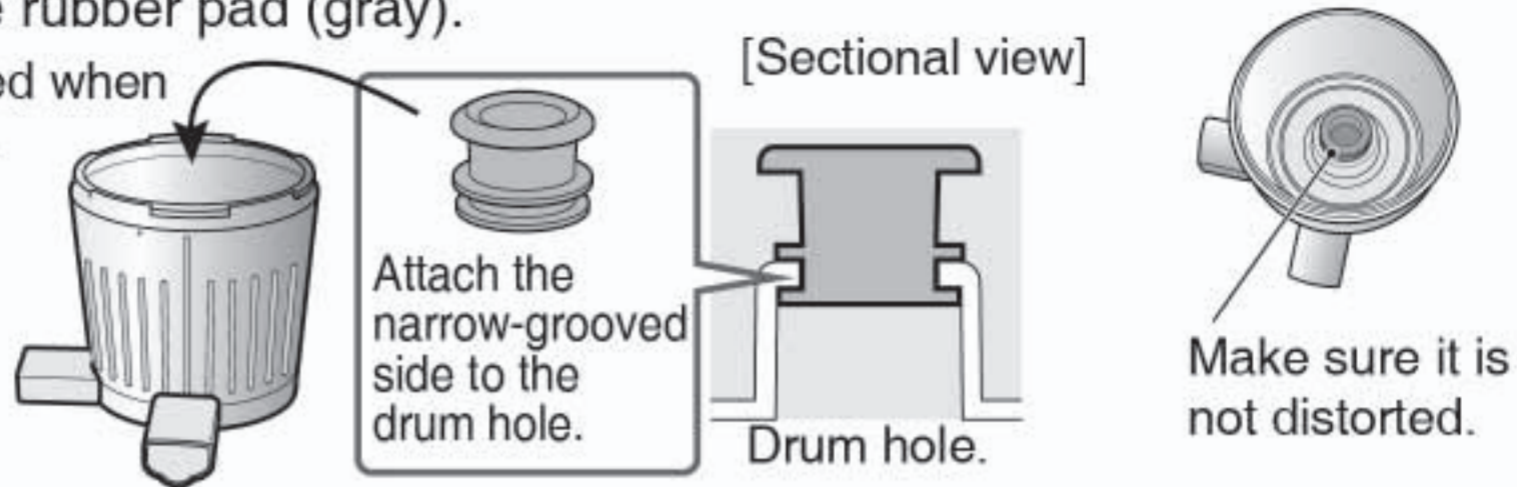

2 Insert the rubber pad (yellow). Wetting the rubber pad makes insertion easier.

※ It is attached when purchased.

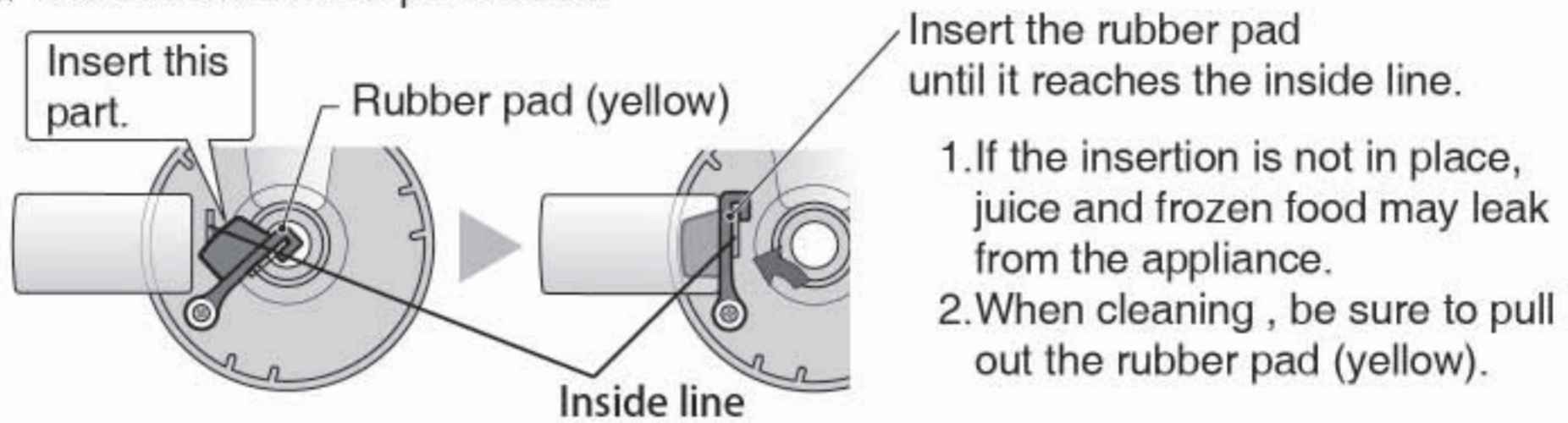

3 By aligning the recess of the drum to the protrusion of the main body, set the drum on the main body.

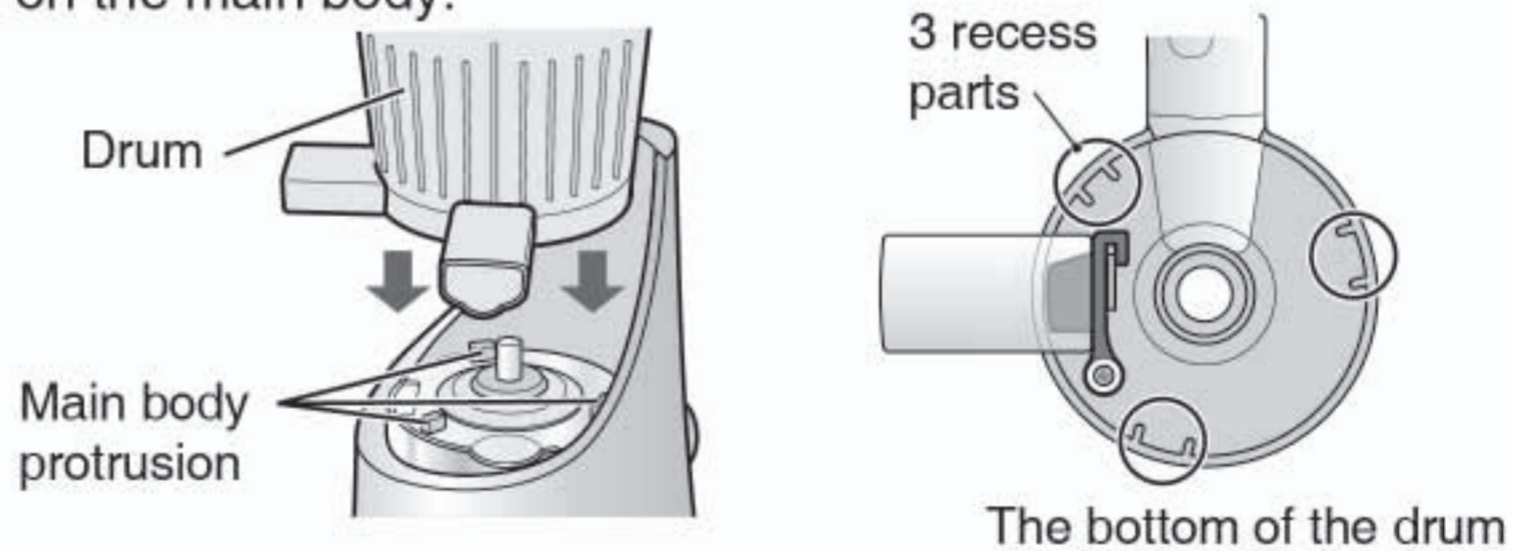

4 Attach the rubber pad (gray) to the filter.

※ It is attached when purchased.

Screw

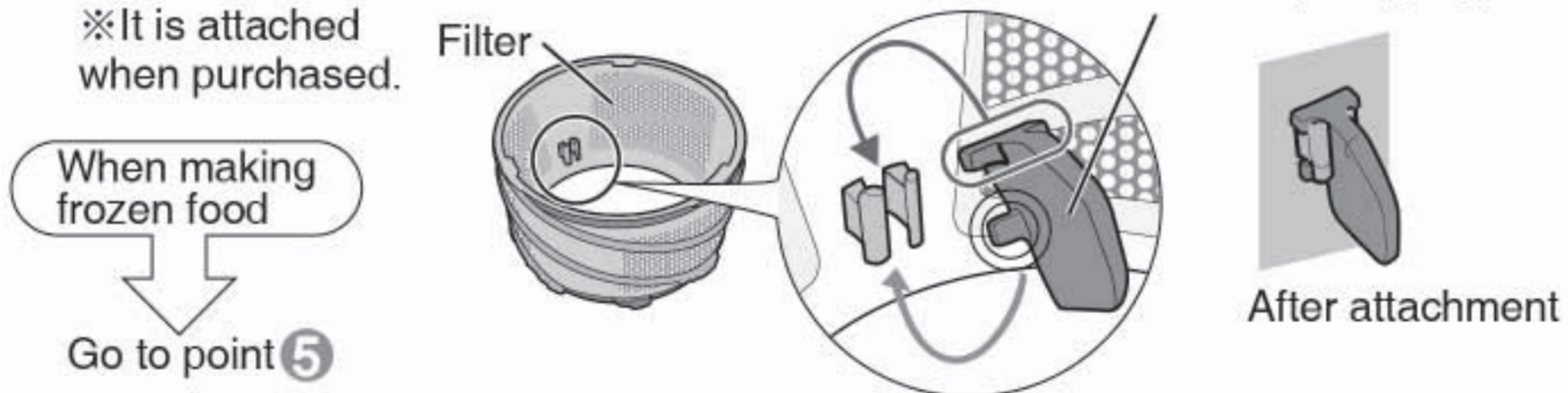

After hooking the part, pull the rubber pad downward to hook it to the lower protrusion .

Assembly Instructions

(how to disassemble)

Disconnect the power cord and assemble the appliance on a stable, flat, dry, horizontal surface.

5 Attach the squeezing screw to the filter.

When making frozen food

Attach the 'frozen food' attachment in place of the filter.



Like the filter installation method

Squeezing screw

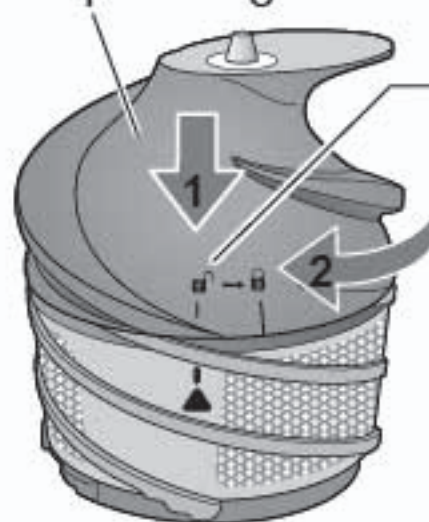

Align the marks. (Also align the marks when disassembling)

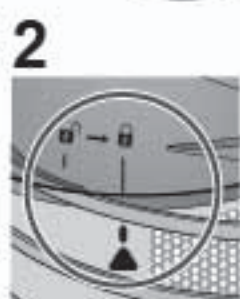

Click



Turn the squeezing screw clockwise and lock it. Ensure that the squeezing screw is securely attached to the filter.

Screw



6 Insert the squeezing screw into the drum and attach it to the rotating shaft.

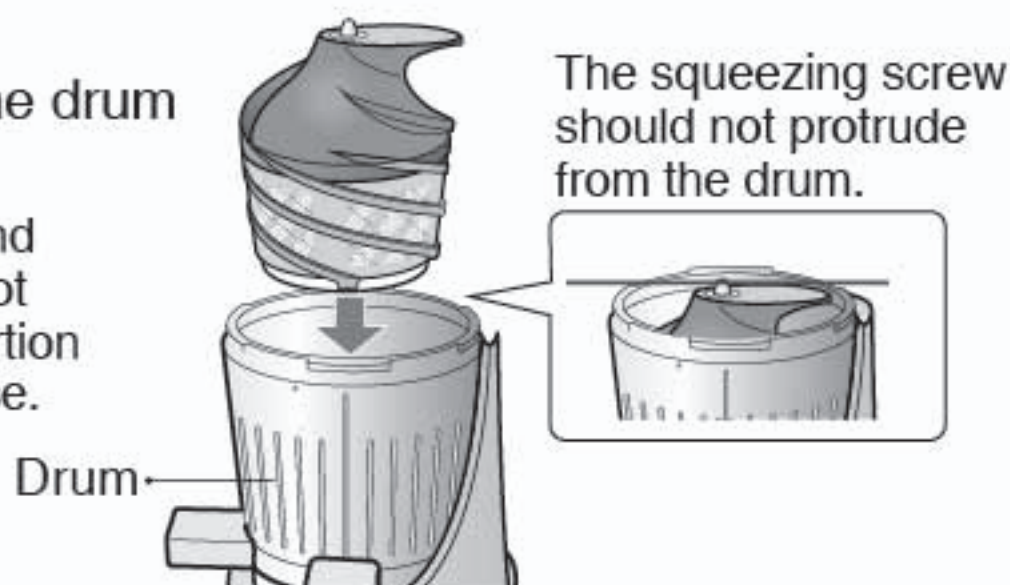

Turn the squeezing screw clockwise and counterclockwise to make sure it will not move downward any further. If the insertion is insufficient, the hopper does not close.

- Be careful not to get your fingers caught between the squeezing screw and the drum.



The squeezing screw should not protrude from the drum.

7 Make sure  on the hopper points to the 'dot' (●) on the drum and turn the hopper clockwise, until the  on the hopper is aligned with the 'dot' (●) on the drum.

-  (open)
-  (closed)

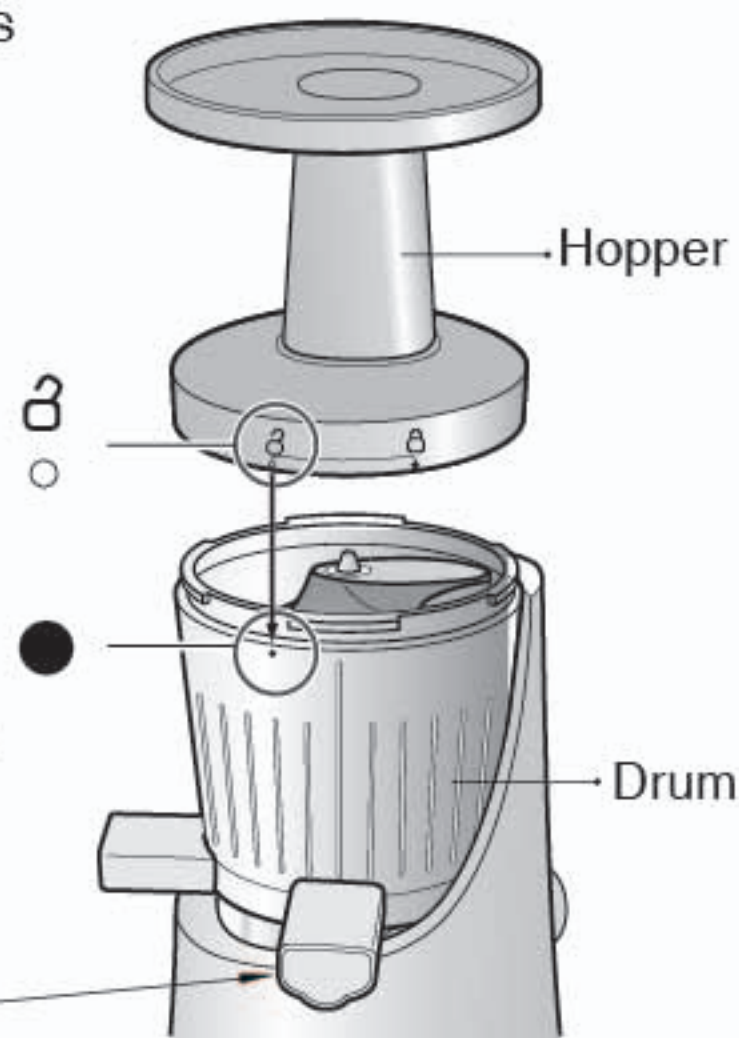
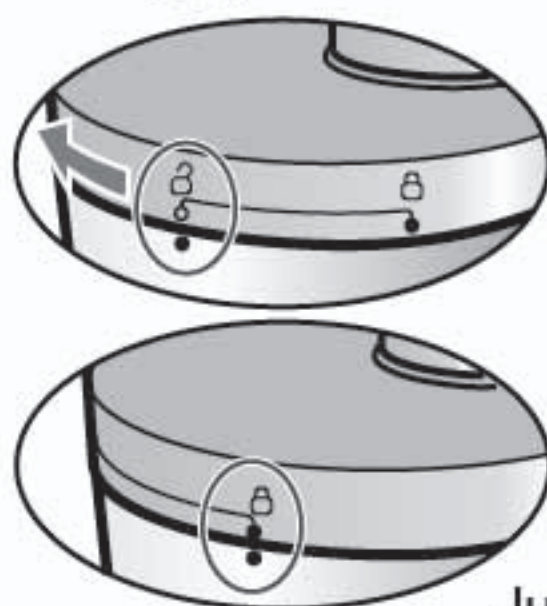

When the hopper is closed, it clicks.

Hopper

Juice cap installation instructions.

- when squeezing juice, you can close the juice cap to prevent the remaining juice dripping.
- When making frozen food, please install the juice cap and make sure it is closed.



Juice cap

How to Use

To prevent a leak, make sure the rubber pads (yellow, gray) are correctly attached. See E-4 page. There is a filter net for juice and a frozen food attachment for frozen food. Please set either the filter or the attachment correctly for intended use of the appliance.

Squeeze juice

For preparing ingredients, see pages E-2~4 of the Cookbook.

- 1 Set the 'juice' filter.
See E-4~5 page

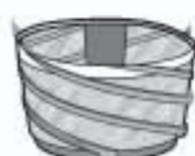

- 2 Place the juice pitcher and pulp pitcher below the juice outlet and the pulp outlet.

- 3 Open the juice cap.

- 4 Connect the power cord.

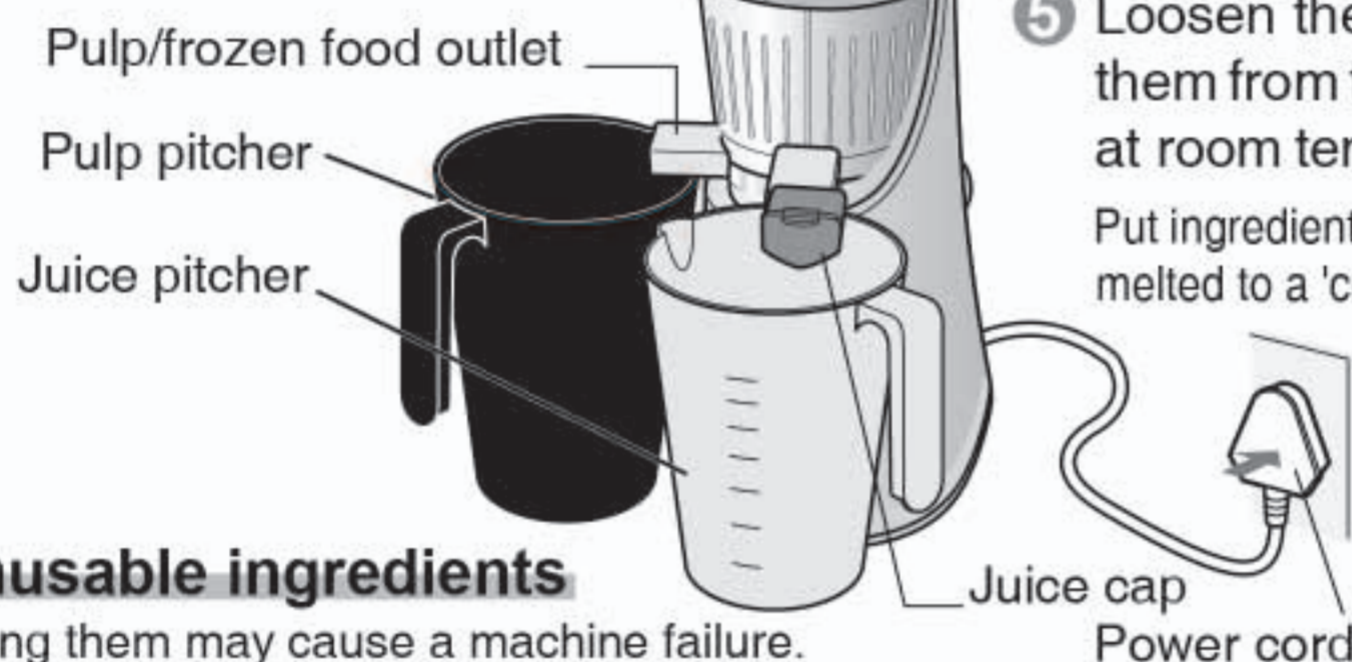

Unusable ingredients

Using them may cause a machine failure.

- Ice • Sugarcane, Beans such as dried soybeans
- Seed of peaches, etc. • Frozen ingredients
- Persimmon (The seeds may not be completely removed) • Dried ingredients that are not suggested in the recipes. (They may damage parts of the appliance.)

Tips

- Ingredients should be put into the machine, little by little, at short intervals. When using ingredients in combination, add them alternately, so that they can be easily made into juice.
- If you put too many ingredients into the machine at one time, the squeezing screw may become clogged, making the production of juice difficult. If the appliance becomes clogged, remove the material and clean the appliance.
- Fruit pulp may be blended into the juice. If you want to remove the pulp, pass the juice through a sieve before tasting it.
- Rinse every fruit or vegetables thoroughly before putting them into the machine.

Make frozen food *

For preparing ingredients, see pages E-13 ~14 of the Cookbook.

- 1 Set the 'frozen food' attachment. See E-4~5 page

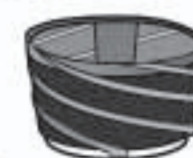

Do NOT use the 'juice' filter for making frozen food, as it may damage the filter.

- 2 Place the pitcher below the frozen food outlet

- 3 Make sure the juice cap closed.

- 4 Connect the power cord.

- 5 Loosen the ingredients after taking them from the freezer and leave them at room temperature for 2 to 3 minutes.

Put ingredients into the machine after they have melted to a 'crisp' level that allows cutting with a knife. If you cannot cut the ingredients with a knife, leave them at room temperature for a little longer.

* Use frozen fruits, vegetable, yogurt and other frozen food, install 'frozen food' attachment to make frozen food

Unusable ingredients

Using them may cause a machine failure.

- Ice • Sugarcane,
- Seed of peaches, etc.

Tips

- To prevent the drum from becoming stuck, when you have added about 300g of ingredients, clean the inside of the drum.
The timing for cleaning is when the amount of produced frozen food exceeds the 200ml scale of the pitcher.
- Frozen food may remain in the drum or the 'frozen food' attachment. If frozen food remains, remove it with a spatula or other soft tool.

How to Use

- 1 Press "ON" (upper part) of the power switch.

To prevent 'idle operation', after starting, immediately put ingredients into the machine.

Switch
upper part

Switch
lower part



Press the upper part of the switch.

- 2 Put your ingredients into the slot, little by little, at short intervals

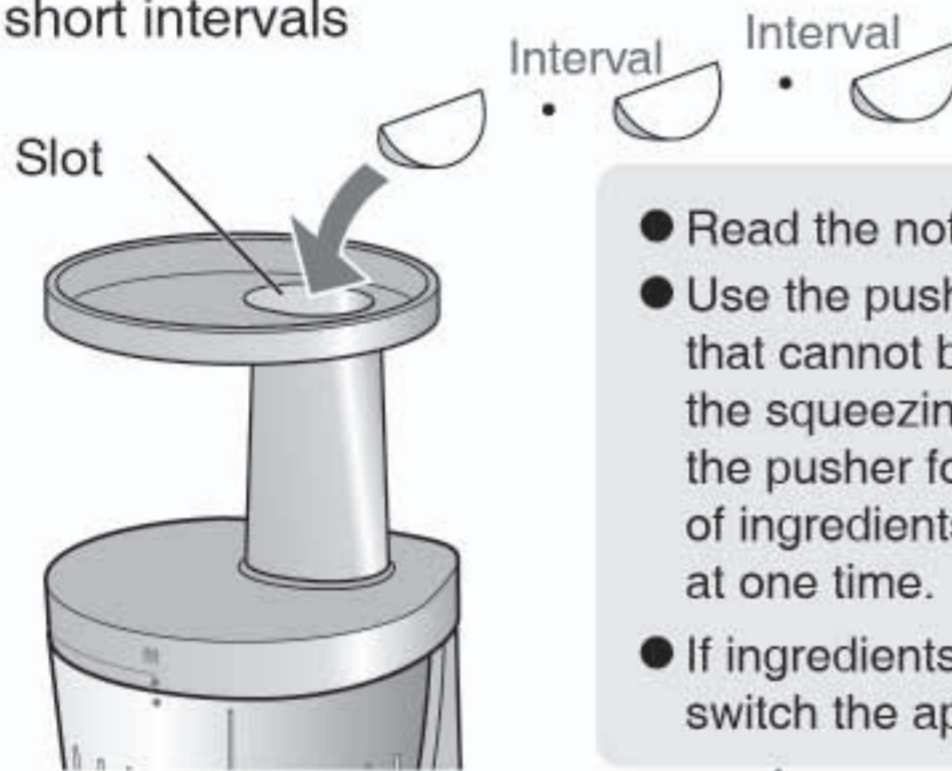

- Read the notes about ingredients. (E-8~9_{page})
- Use the pusher when forcing ingredients that cannot be smoothly taken into the squeezing screw. Please do not use the pusher for forcing excessive amounts of ingredients into the squeezing screw at one time.



- If ingredients become stuck, or the machine is idling, switch the appliance into 'reverse' mode. (E-8_{page})

When making juice

The squeezing screw slowly takes in ingredients, while the juice and pulp are ejected from the respective outlets. Depending on freshness and harvest period of your ingredients, the amount of juice produced will vary. If it becomes difficult for the pulp to be ejected, press the "OFF" switch once, remove the ingredients and clean the appliance.

We recommend not to juice fruits and vegetables over 1kg at once as the pulp may be blended into the juice. Refrigerate the unused leftover juice.

When making frozen food

After ingredients have been drawn into the 'frozen food' attachment, put the next ingredients into the machine.

The squeezing screw takes in ingredients slowly, and the frozen food comes out of the frozen food outlet. If the rotation of the squeezing screw slows down, cease adding ingredients into the machine for a few moments. Once rotation returns to normal, you can resume putting ingredients into the appliance.

- 3 When squeezing has finished, tap the "OFF/REV" control of the power switch lightly to stop the machine.



Press the lower part of the switch

- Please note that when you press the lower part of the power switch firmly, reverse rotation mode starts.
- After use, disconnect the power cord and clean the machine. (E10_{page})
- When making frozen food, remove the ingredients remaining in the drum with a spatula or similar soft tool.

Helpful Tips (Reverse Mode)

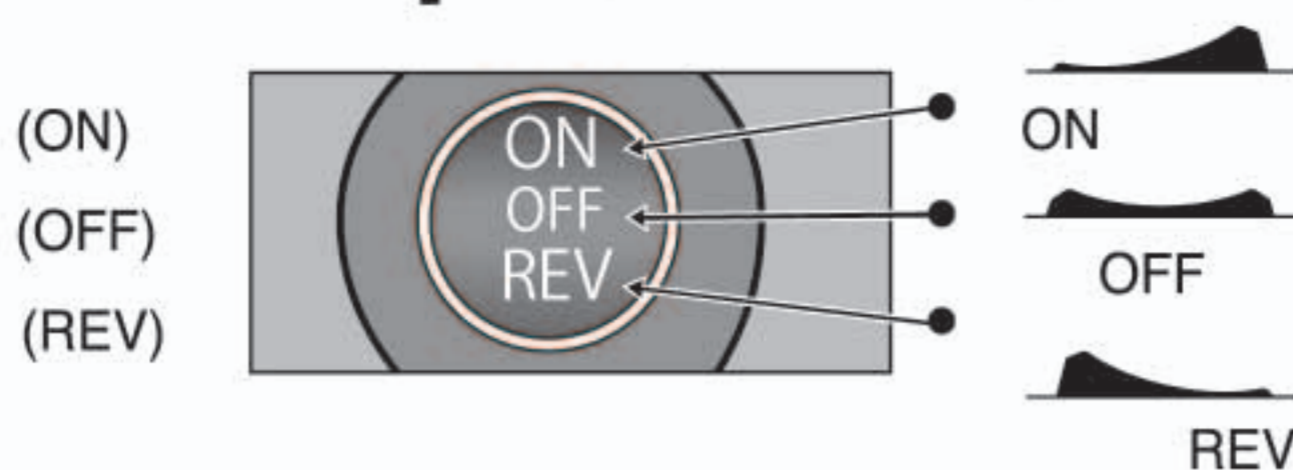

1. Turn off the machine.
2. Run the product in “(REV)” mode for a few seconds.
3. Operate the product again.
4. If “(REV)” mode is inoperable, turn off and disassemble the product. Then, reassemble the product by instructions.
5. Activate the product again.



The power button should be completely dried before the product is operated.

Ingredients

Squeezing juice E6~E7 page

- Use fresh ingredients.
- Citrus fruits, such as tangerines, oranges, and lemons
 - Peel the skins and divide the fruit into suitable sizes. Ingredients with small pips and thin skins can be put into the machine.
- Fruits that are usually peeled before eating, such as pineapple, bananas and kiwi fruit
 - Peel the skins.
- Food materials with hard cores such as pineapple and corn
 - Remove the cores.
- Vegetables that are eaten with their skin, such as carrots, radish and ginger
 - They can be put into the machine without peeling.
- Watermelon, melon
 - Peel the skins. They can be put into the machine with seeds remaining.
- Apples
 - Remove the stem end and cut the apple into wedges.
 - ※ Fruits that easily turn brown, such as apples, will also turn brown after juicing with the passage of time.
- Stone fruits, such as peaches
 - Remove the stones. They can be put into the machine without peeling.
- Vegetables with a high fiber content, such as Japanese mustard spinach, cabbage, and kale
 - Cut the vegetables into smaller pieces.
 - Japanese mustard spinach and cabbage form bubbles of foam on the surface of the juice. You can taste the juice without removing the foam, or use a spoon for removal.

Ingredients

Squeezing juice E6~E7 page

Tips for adding ingredients (Squeezing juice)

- Note that, when you have put ingredients into the machine or have removed the hopper, juice may be scattered about your workspace.
- Since soybeans (just boiled) and bananas have a low water content, put them through the slot, together with water and/or milk, or else they may not be juiced properly.
- Since carrots have a low water content and a large amount of fiber, they produce a lot of pulp.
- When juicing leafy vegetables, combining them with fruits that have high water content makes the squeezing easier.
- When juicing vegetables that have leaves and stems, put the leaves and stems alternately into the machine.
- When juicing bananas, kiwi fruit and strawberries, much of the fruits' flesh component will be contained in the pulp.
- Leafy green vegetables, such as Japanese mustard spinach and cabbage or other thinly-sliced ingredients, may be caught between the squeezing screw and the drum and make the juicing process difficult. In such a case, use reverse mode for a few moments. E8 page
- Cabbage may cause a large noise during operation.
- Dry ingredients cannot be used. When using soybeans, use boiled or well-soaked beans.
- Small seeds (of apples, grapes and watermelon) can be put into the machine together with the flesh of the fruit. Large, hard stones (peaches, etc.) should be removed.

When making frozen food E6~E7 page

- Use pre-frozen ingredients.
- Cut ingredients to a size that fits into the slot and put them into freezer bags and freeze the contents flat so that the ingredients do not overlap. When ingredients have stuck together, break them apart by hand, before putting them into the machine.
- When freezing soft materials like yogurt, it is convenient to use ice cube trays. (Ice cube trays should not be used for liquids such as water or juice.)
- Citrus fruits such as tangerines and oranges
 - After peeling the skins and removing the pips, cut the fruits into wedges.
 - Peeling thin skins makes the cutting smoother.
- Pineapple, kiwi fruit
 - Peel the skins and remove the cores, if there are any.
- Canned food
 - Drain excess liquid.
- Apple, paprika, tomato
 - Remove the stem ends, cores, and seeds. Peeling the skins makes the cutting smoother.
- Carrot, pumpkin
 - Cut the vegetables into 2cm cubes and boil them for a short time.
- Spinach
 - Boil spinach and cut it into pieces 2 to 3cm long.
- Commercially available frozen fruits
 - Frozen fruits can be used as they are.
- Commercially available cut fruits
 - Remove the skins and seeds.
- Bananas
 - Peel the skins and cut the fruit into 2cm round slices.

Tips for adding ingredients

- Ingredients, immediately after being taken out of the freezer, should not be used. Leave them at room temperature for 2 to 3 minutes. Put ingredients into the machine after they have melted to a 'crisp' level that allows cutting with a knife.
- Please do not look into the slot during operation, as ingredients may be ejected at high speed
- Hard ingredients may cause a large noise during operation.
- If the rotation of the squeezing screw slows down, cease adding ingredients into the machine for a few moments. Once rotation returns to normal, you can resume putting ingredients into the appliance.

How to Disassemble and Clean

1 Turn machine "OFF", cut off the power.

2

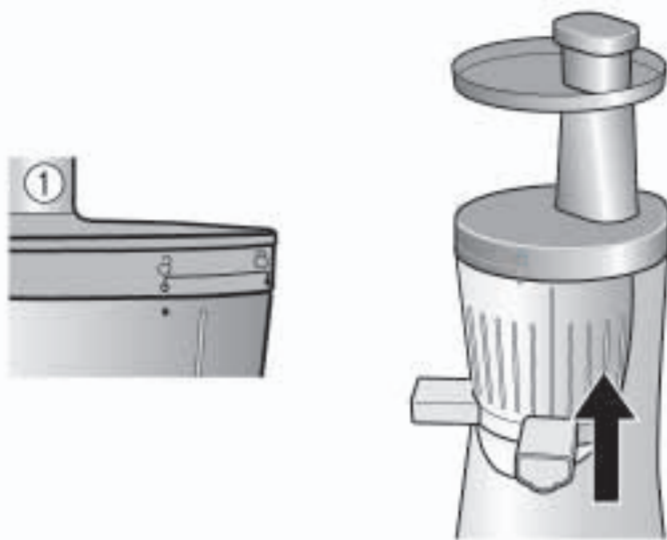

Grab and twist the hopper to unlock. Make sure 'open dot' (○) on the hopper is aligned with 'dot' (●) on the drum before pulling off the drum.

3



Disassembly order

- ① Hopper
- ② Squeezing Screw
- ③ Drum



Warning

When you turn in reverse in squeezing, the top and bottom of the squeezing screw may be separated, and be careful about the falling at the time of disassembly.

4

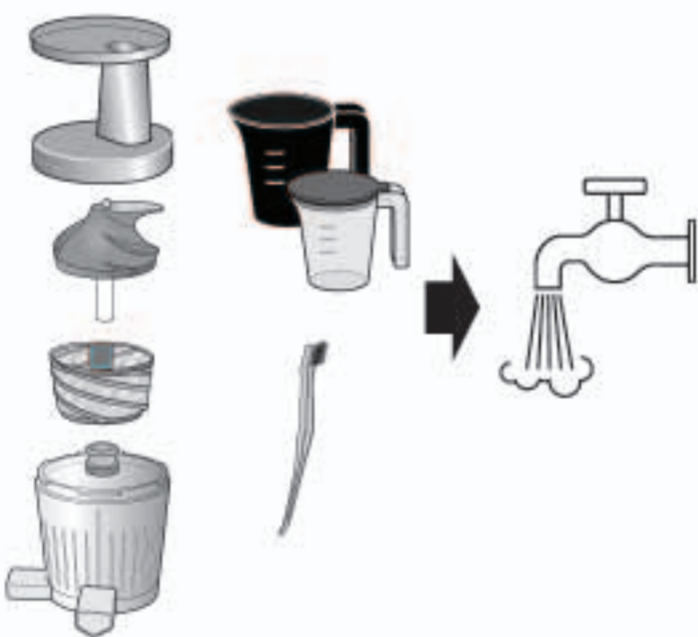

Use the brush to clean the squeezing screw thoroughly after operating.



Warning

Use smooth and wet towel for cleaning. Do not use dishwasher or high-temperature cleaner for cleaning.

Because the squeezing screw is heavy, please carry it to the washing place with putting it in a drum.

5



Warning

Do not dry the product parts with heating appliance. To reduce mould build up ensure all removal parts are cleaned thoroughly.

Cleaning Tips

You can clean the squeezing screw after disassembling it.

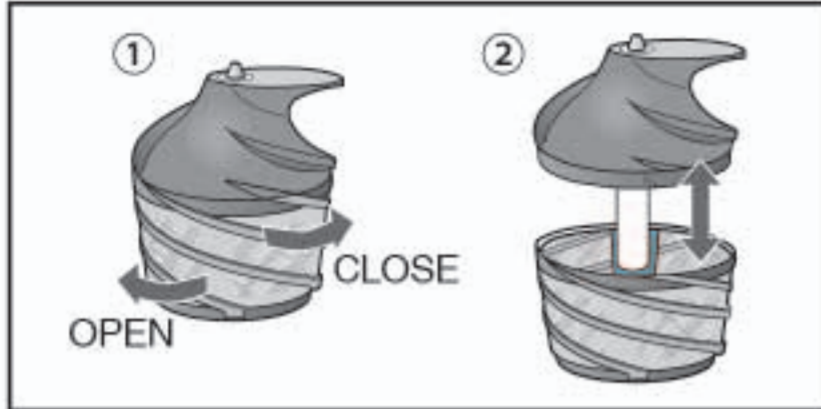

The decomposition method is as the left.

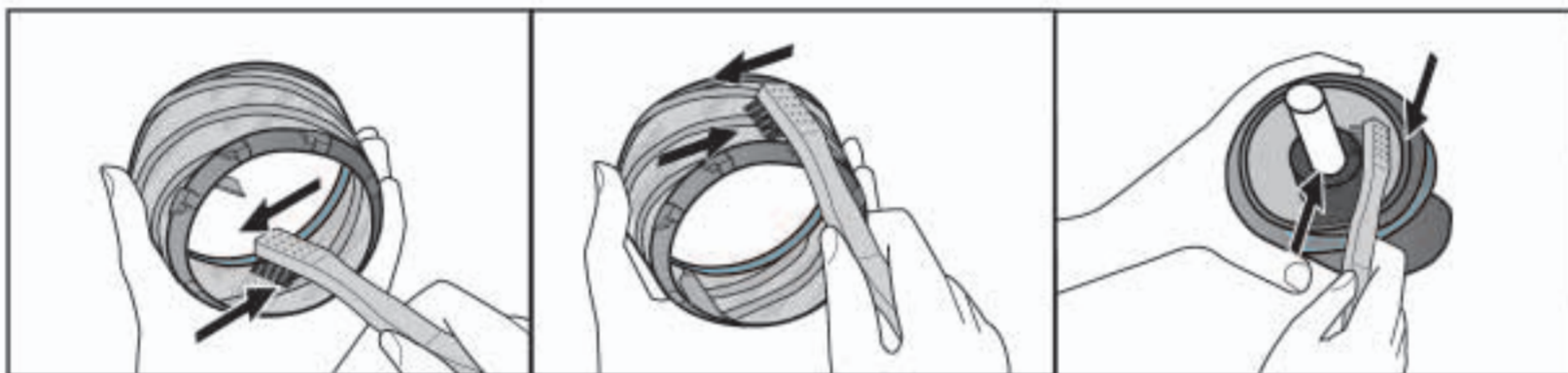

Clean both the inside and the outside of the strainer and inside the squeezing screw with enclosed cleaning brush.

Clean immediately after use.



Rinse the squeezing screw and strainer under running water to remove any trapped or remaining pulp.

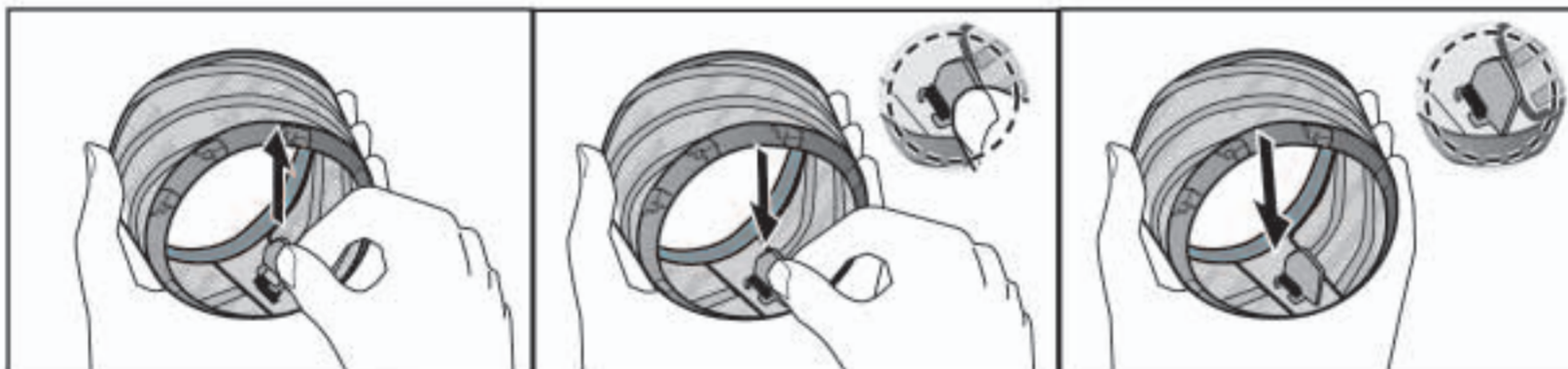

Pull out the rubber pad gently.

Insert the bottom of rubber pad first.

Then push in upward the rubber pad.

Removing the rubber pad will allow you to clean the interior of the strainer thoroughly.



- Do not use detergents that contain organic solvents (solvent, thinner, etc), bleach, chlorine, benzene or abrasives to clean any part of juicer.
- Do not keep the product without cleaning after use. Always clean immediately after use.
- Do not rinse or submerge the main body in water or other liquid.
- Use a clean, soft towel to clean the main body, if needed.

Troubleshooting

Users might improperly operate the product due to their unfamiliarity with how to use the product. Check the following items to resolve such issues. If issues cannot be resolved using these procedures, please contact the service centre.

Problem	Check	Possible Solutions
The product is not working.	• Is the power cord connected?	Check whether the power cord is plugged into a 220-240V, 50 Hz wall outlet.
	• Is the Juicer assembled correctly?	Assemble the product as described in this operation manual (refer to E-4).
	• Has the power gone off?	
	• Have you operated the Juicer for over 20 minutes?	Turn off the product. Wait for a while and reactivate the product. If you want to use the product continuously, pause the operation for 1 hour.
The juice is too thick or thin.	• Did you assemble the rubber pad correctly?	Assemble the rubber pad as described in this operation manual (refer to E-3 'Rubber pad installation').
	• Did you use fresh ingredients?	Overripe fruits or vegetables may clog in the motor. If you want to use the overripe ingredients, use them after soaking in mineral water for 10 minutes or more.
	• Did you put too many ingredients or anything else into the machine?	Do not put too many ingredients or liquids into the machine. We recommend you to clean the machine after 1 kg of juicing. Disassemble the Drum and wash it.
The Drum cover is too hard to open.	• How did you open the Drum cover?	Press the " (REV)" button and open the Drum toward " (⌚)". * Check directions when opening the drum. * When making the frozen food, please open hopper after waiting for a while; because it is easy to open after melt of ingredients.
The product stops while in operation.	• Did you force food into the juicer?	Do not insert too much ingredients.
	• Did you put the ingredients with hard seeds?	Press the " (REV)" button for 2 to 3 seconds and then press the " (ON)" button again. * After following the step above, if the Squeezing Screw does not rotate, stop using the product. Turn off the product, disassemble and clean it. Then reassemble and use your Juicer again.
The motor is running with loud noise and shaking.	• Did you check that all parts are assembled properly and in correct position?	If the product is assembled properly, it is normal to make noise in juicing from overripe fruit and vegetables. Turn the product off and clean the receptacle.

Troubleshooting

Problem	Check	Possible Solutions
The motor is running with loud noise and shaking.	<ul style="list-style-type: none"> In the making of frozen food, can the ingredients be put when it can be easily cut by kitchen knife? 	In the process of putting material, when the frozen ingredient is put into Frozen food attachment for making fruit ice, then other ingredient can be put in the machine.
Juice cannot be squeezed out easily.	<ul style="list-style-type: none"> Sometimes, some materials such as leaf vegetable are hard to be squeezed out juice in operation. 	Please conduct reverse operation. (See E-8)
If fruit pulp contains lots of water	<ul style="list-style-type: none"> Please check whether the filter is blocked. (Page E-11) 	
The receptacle is vibrating in use.	<ul style="list-style-type: none"> This is normal to make juice. If the product overheats, contact the local service centre. 	
If juice leakage is found in gap between the main body and drum	<ul style="list-style-type: none"> Please check whether the rubber pads (yellow, gray) of drum is installed correctly. (See E-4) 	
If the cover of drum cannot be matched	<ul style="list-style-type: none"> Please check whether rubber pads (gray) of drum is installed correctly. (See E-4) Please check whether squeezing screw and filter (or Frozen food attachment) are installed correctly. (See E-5) Please check whether the squeezing screw is fully installed on the drum. (See E-5) 	

Product Specification

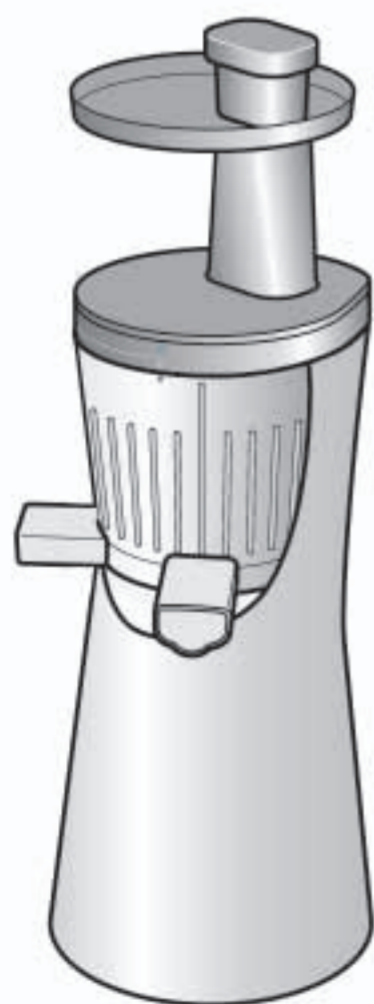

Specification

Model Name	EJ-X20H	
Rated Voltage	220-240V	
Rated Frequency	50 Hz	
Rated Input	150 W	
RPM	32 Rpm	
Electrical cord length	1400 mm	
Motor	DC Motor	
Weight	Net	4.8 kg
	Gross	6.5 kg
Dimensions	Width	150 mm
	Depth	177 mm
	Height	447 mm
Rated usage time	Less than 20 minutes continuously	

慢磨果汁機

Slow Juicer

EJ-X20H

操作說明書 Operation Manual

原產地: 韓國
Made in Korea

韓國印刷
Printed in Korea